



DREAM BIG PACK SMALL

TIWAL 3R
Owner's manual



TECHNICAL SPECIFICATIONS

TIWAL 3R



BOAT TYPE

Dinghy

CATEGORY

D*

LENGTH OF THE HULL

10' 6"

WIDTH OF THE HULL

4' 6"

WIDTH OF THE HULL WITH SIDE WINGS

5' 4"

TOTAL WEIGHT

121 lbs

MAX. ENGINE POWER

0 cv

MAX. NUMBER OF PASSENGERS

2 adults or 1 adult and 2 children

MAX. LOAD (PASSENGERS + LUGGAGE)

440 lbs

SAIL SURFACE AREA

67 ft² or 77 ft²

MANUFACTURER

TIWAL

ID NUMBER

The CIN (Craft Identification Number) or HIN (Hull Identification Number) is registered on the aft starboard part of the inflatable hull.

United States: HIN starting with TIW...

Europe: CIN starting with FR...

* Category D: Designed for voyages on sheltered coastal waters, small bays, small lakes, rivers and canals where conditions up to wind force 4 with and significant wave heights up to 18 inches.

You are the owner of a TIWAL 3R dinghy made by TIWAL. This manual will advise you how to find both enjoyment and safety in navigation. Inside you will find technical specifications, assembly instructions, maneuvers and recommendations for maintenance.

If the TIWAL 3R is your first dinghy or one that you aren't accustomed to, we recommend that, at first, you familiarize yourself with its operation in calm weather conditions. Get in touch with your local sailing clubs or schools for advice regarding possible instruction.

READ THE MANUAL IN DETAIL BEFORE USING THE TIWAL 3R TO FAMILIARISE YOURSELF WITH ITS OPERATION AND HANDLING.

Make sure that prevailing wind and sea conditions are suitable for the boat's design category, and that you and your crew are able to navigate the boat in these conditions.

This owner's manual is not a detailed guide for maintenance and repair. If you are experiencing difficulties, please get in touch with the manufacturer or a representative.

Always seek out the services of an experienced professional for maintenance and whenever fitting accessories or making modifications. All modifications that could impact

the safety characteristics must be evaluated, executed and documented by competent professionals. TIWAL SAS cannot be held liable for modifications that are not approved by the manufacturer. Certain countries require a permit or authorization for navigation or require that specific rules be followed.

Always perform the suggested maintenance on your boat and take into account that wear and tear will result over time or, as the case may be, from frequent or inappropriate use. Any boat (however sturdy) can be severely damaged if it is subject to inappropriate use. This is incompatible with safety in navigation.

Always adjust the boat's speed and direction to prevailing conditions. On board, the crew must have access to certain safety equipment (life-vests, etc.) that is suited to the type of boat, the weather conditions, etc. Such safety equipment is legally required in certain countries. The crew must be familiar with the use of this equipment and with emergency safety maneuvers (man overboard, towing, etc.); regular training sessions are available through local sailing clubs and schools.

PLEASE KEEP THIS MANUAL AND GIVE IT TO THE NEW OWNER IF YOU CHOOSE TO SELL THE BOAT

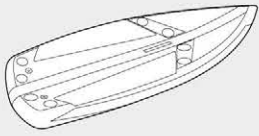

PVC HULL
2HULL01



x2 **WEBBING STRAP**
2WEST01

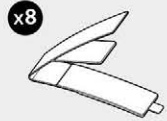

x8 **HOOK AND LOOP STRAP**
M (x6) 2VELC01
L (x2) 2VELC02



TOE STRAP
2TSTR01
+ **BUNGEE** 2SAND601
+ **ROPE** 2ROP601



HIGH PRESSURE HAND PUMP
2HPPH01



ELECTRIC PUMP
2LEPE01

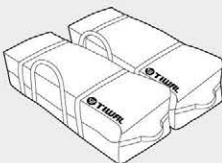

CARRY BAGS
2BAGB01

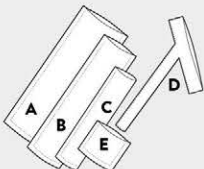

PROTECTIVE COVER
A 2PCOV01
B (x2) 2PCOV06
C 2PCOV08
D (x2) 2PCOV09
E 2PCOV02



TRANSOM
1TRAN03



COMPOSITE DAGGERBOARD
1DAGG02



COMPOSITE RUDDER
2RUDD02

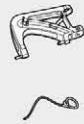

RUDDER HEAD
2CAST01

SAFETY PIN
2SPIN01

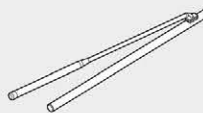

TILLER
2TILL01

TILLER EXTENSION
2STIC01

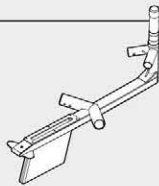

CENTRAL PIECE
1CPIE04

+ **BUNGEE** 2SAND601
+ **TUBE** 2TUBE01



MAINSHEET SWIVEL JAMMER
1SWIV00

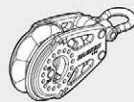

RATCHET BLOCK
2BLOC01

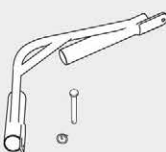

BOW-SHAPED BRACE
1ARCEA01

+ **PIN** 2AXIH000
+ **SAFETY PIN** 2SPIN02

x2



MIDDLE HIKING WINGS
1HIKW01



T3R FRONT LEFT WING
1WIFP02



T3R FRONT RIGHT WING
1WIFS02

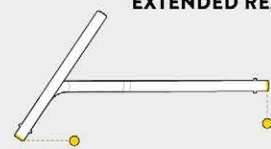

EXTENDED REAR LEFT WING
1WIRP02

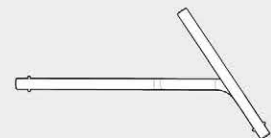

EXTENDED REAR RIGHT WING
1WIRS02

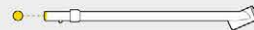

LEFT REINFORCEMENT ARM
1RAP002



RIGHT REINFORCEMENT ARM
1RAST02



CLAM CLEAT
2CLEA01



CLAM CLEAT RING
2CLCL03

x2



ROPEGUIDE RING
2RINFR00

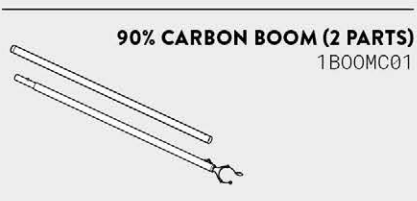

90% CARBON BOOM (2 PARTS)
1BO0MC01

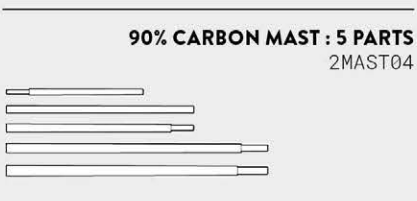

90% CARBON MAST : 5 PARTS
2MAST04

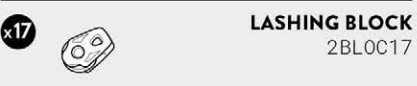

LASHING BLOCK
2BLOC17

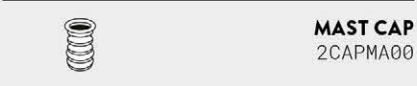

MAST CAP
2CAPMA00

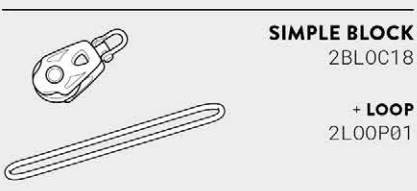

SIMPLE BLOCK
2BLOC18

+ **LOOP**
2L00P01



UPPER MAST RING
2MASRI02



LOWER MAST RING
2MASRI01

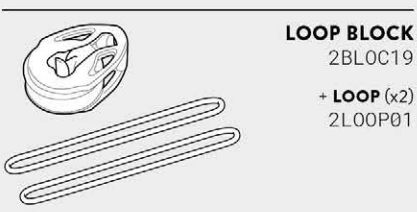

LOOP BLOCK
2BLOC19

+ **LOOP (x2)**
2L00P01



MAST PROTECTION TUBE
2MASPR00



LASHING BLOCK
2BLOC16



BATTEN TRIM KEY
2KEYTR00



TRAVELER BLOCK
2BLOC15

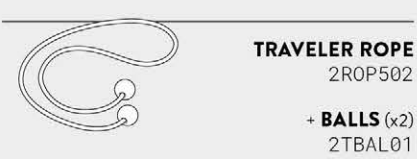

TRAVELER ROPE
2ROP502

+ **BALLS (x2)**
2TBAL01

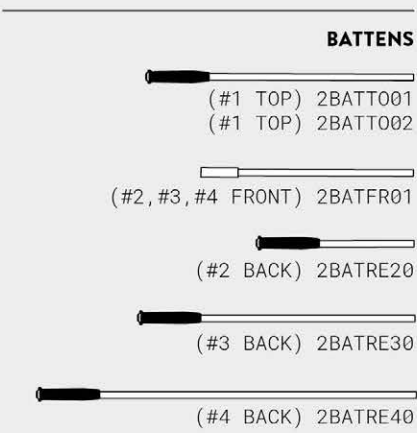

BATTENS

(#1 TOP) 2BATT001
(#1 TOP) 2BATT002

(#2, #3, #4 FRONT) 2BATFR01

(#2 BACK) 2BATRE20

(#3 BACK) 2BATRE30

(#4 BACK) 2BATRE40

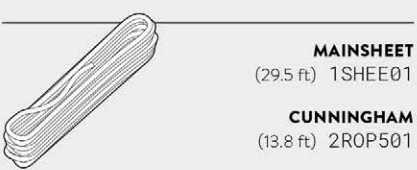

MAINSHEET
(29.5 ft) 1SHEE01

CUNNINGHAM
(13.8 ft) 2ROP501

VANG
(2.5 ft) 2ROP403
(16.4 ft) 2ROP503

BOOM VANG TRAVELER
(9.8 ft) 2ROP505

CLEW OUTHAUL
(8.9 ft) 2ROP402
(14.4 ft) 2ROP504

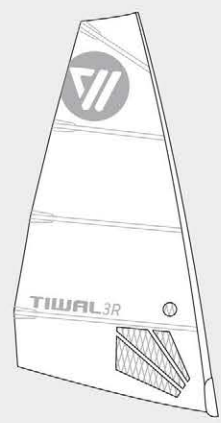

77 FT' SAIL
1SAIL080

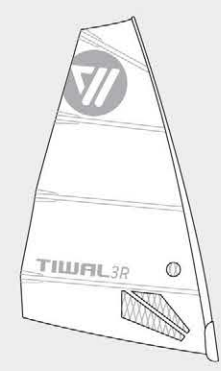

67 FT' SAIL
1SAIL090

ASSEMBLY

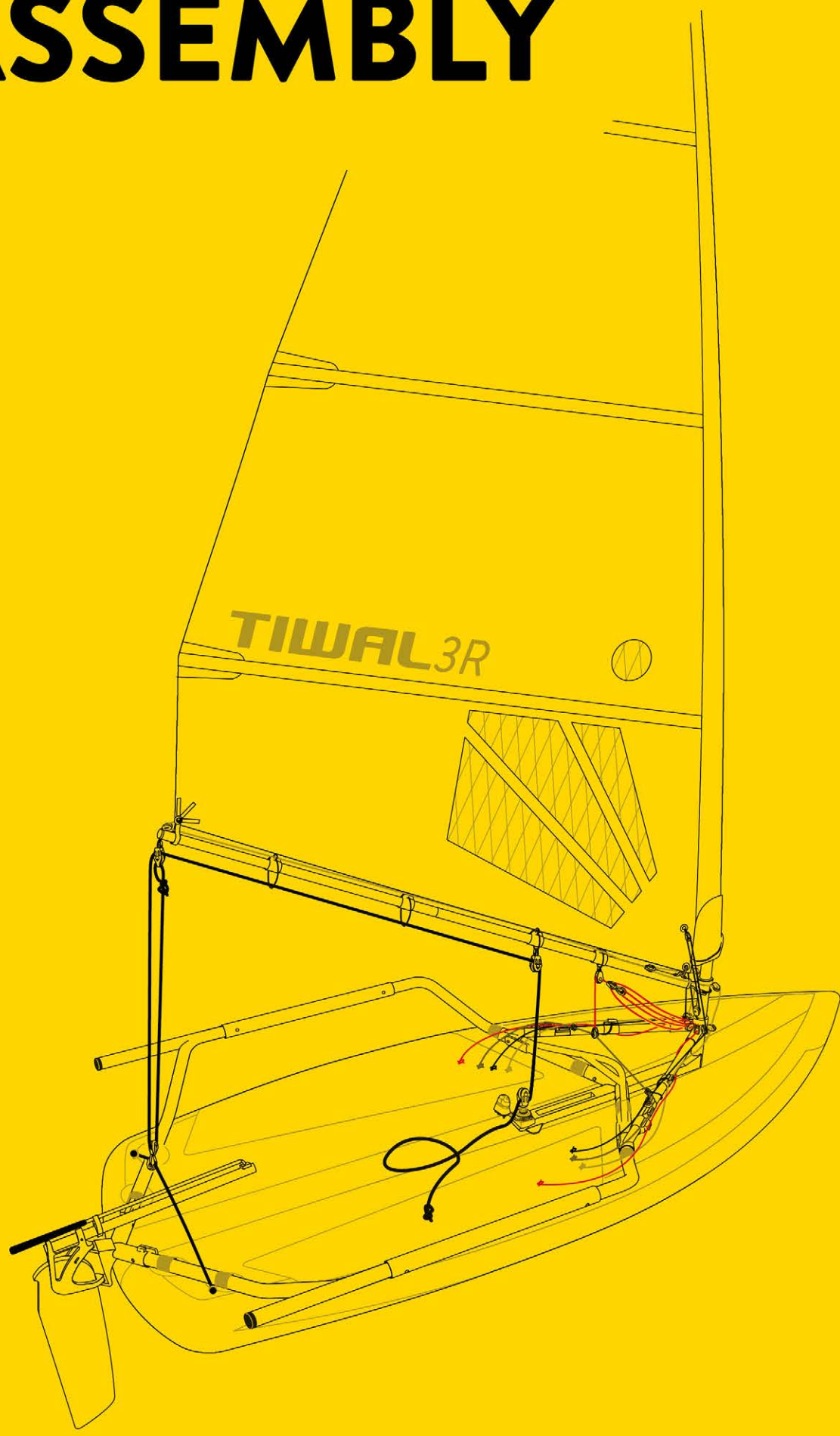

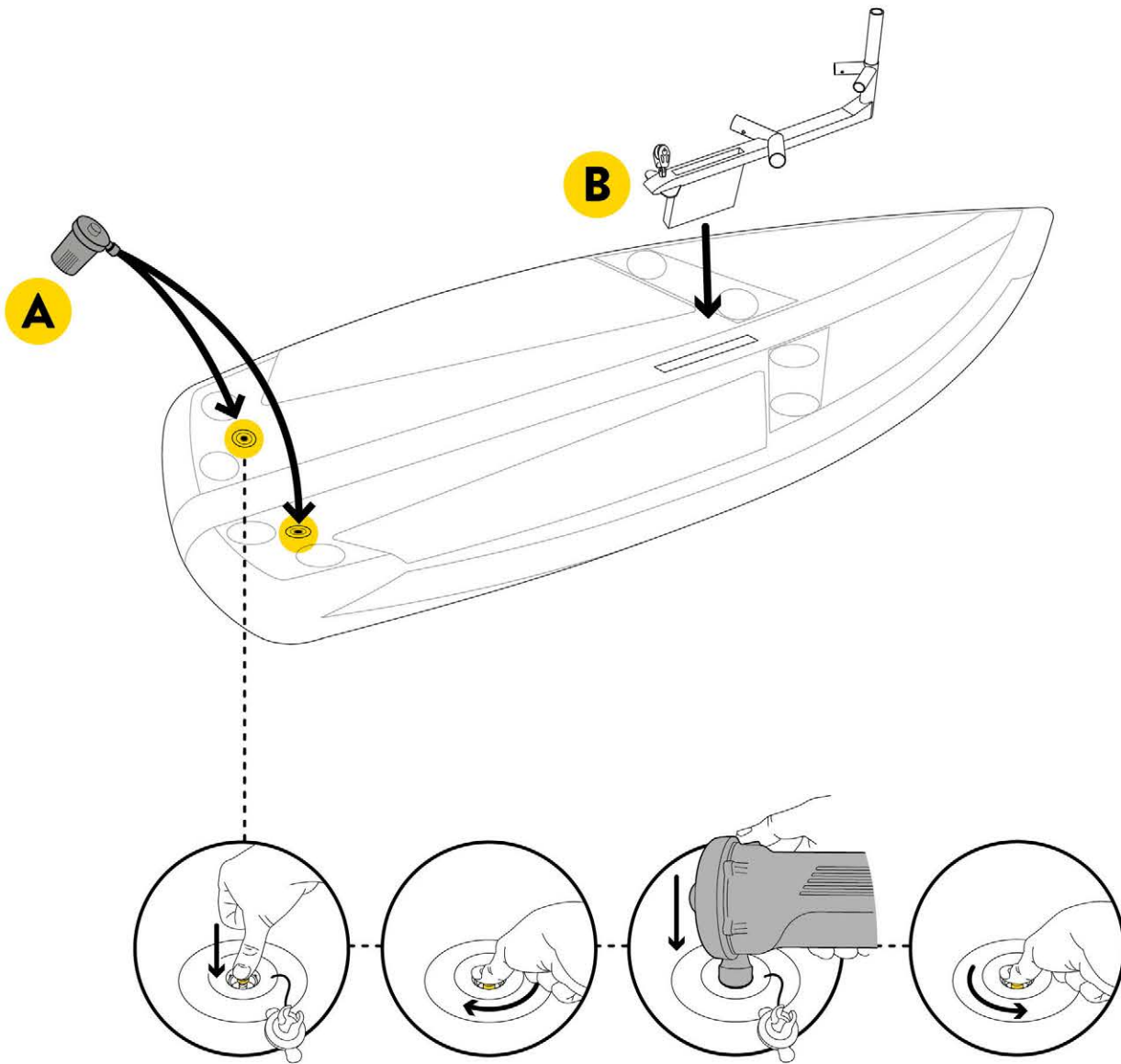
1

- ① Roll out the hull on a surface free from debris that could cause any damage. Inflate the hull with the electric pump until it starts taking shape without being pressurized.
Pression <math><0,1\text{ psi}</math>.

2

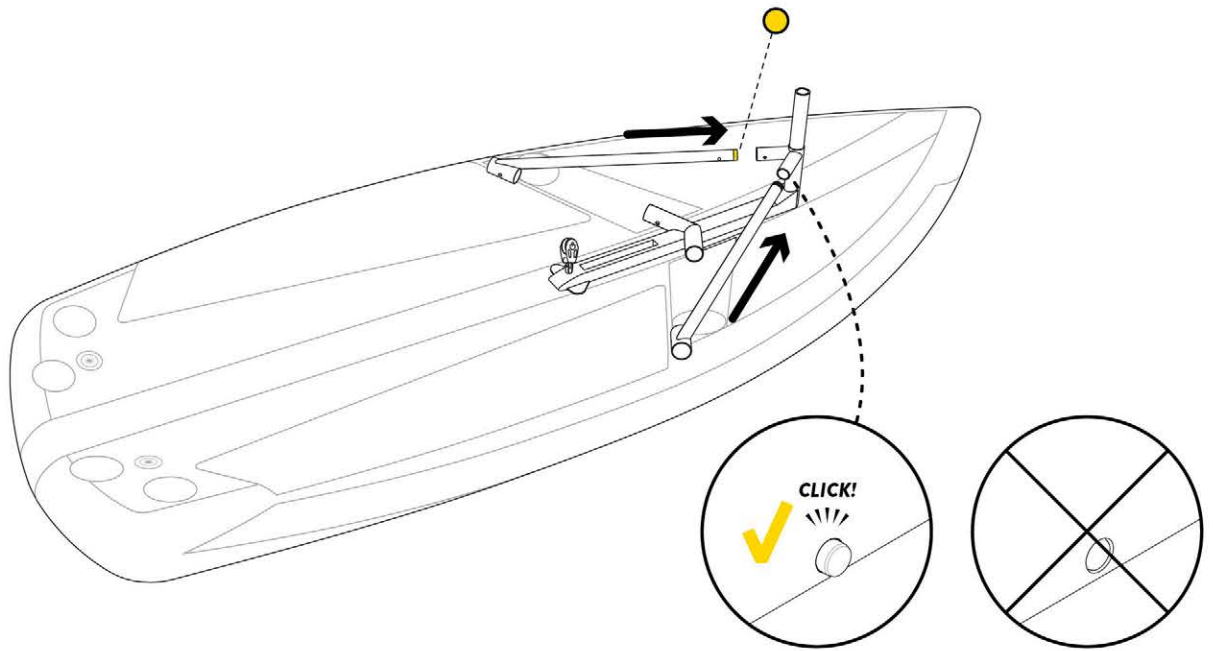

2 Install the framework. The parts with the yellow caps should always be on the left side.

3

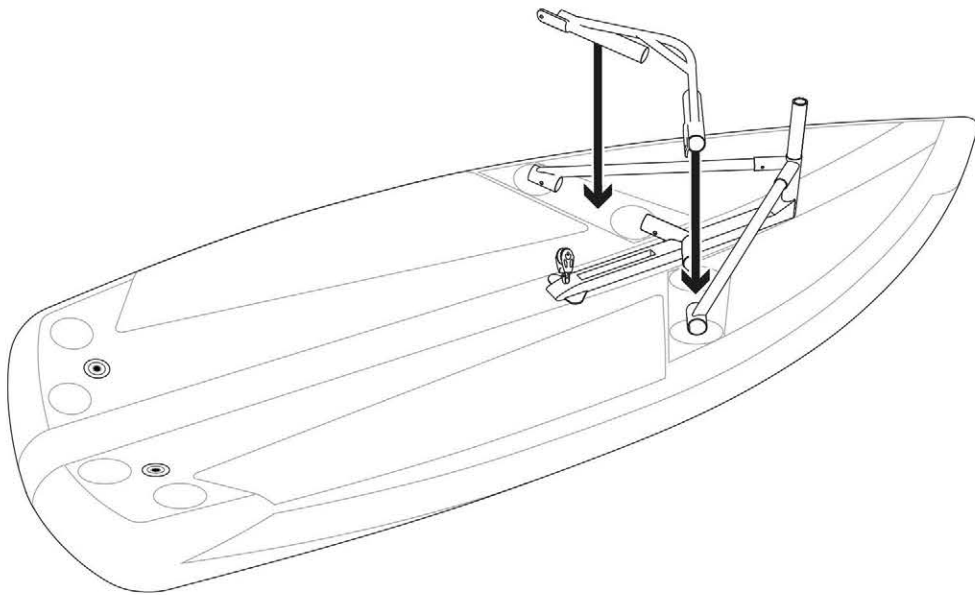

4

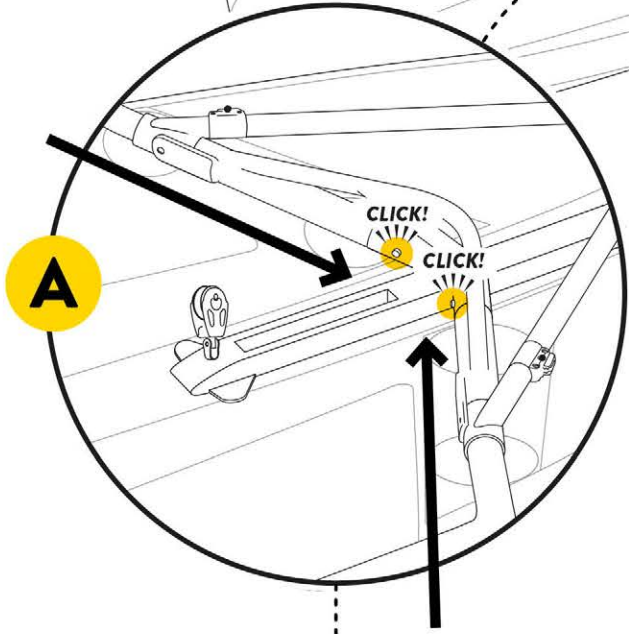
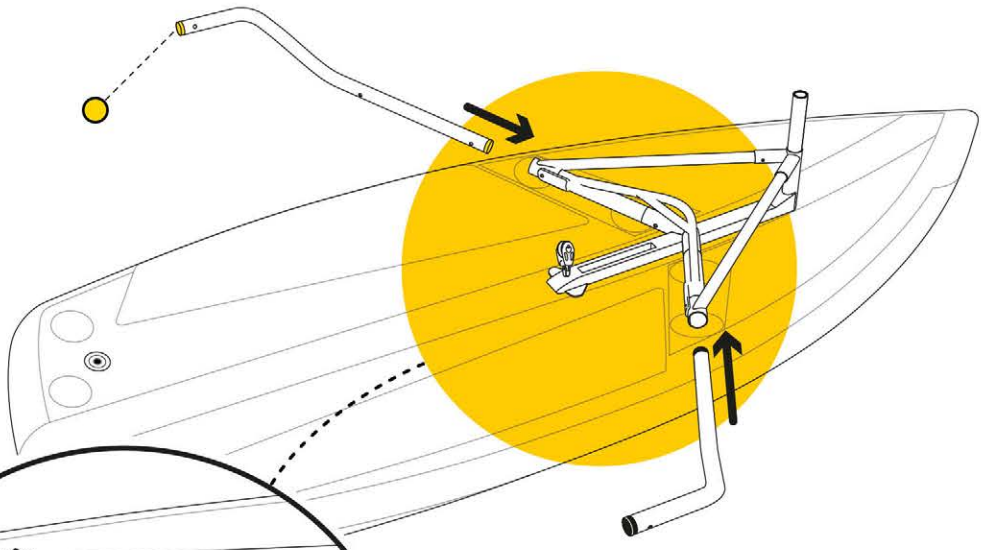

- 4
- A Insert the wing with the push-pins facing up. Once the wing is inserted, rotate so it clips in.
 - B Insert the two pins.
 - C Attach both pins with the safety pins connected to the framework.

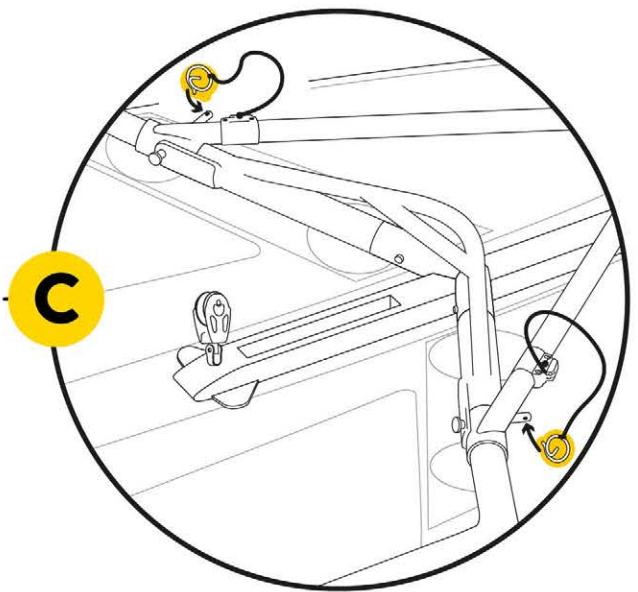
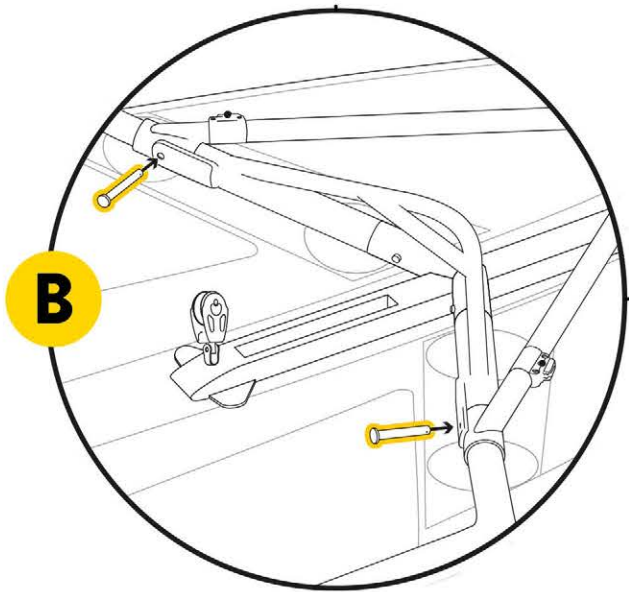

5

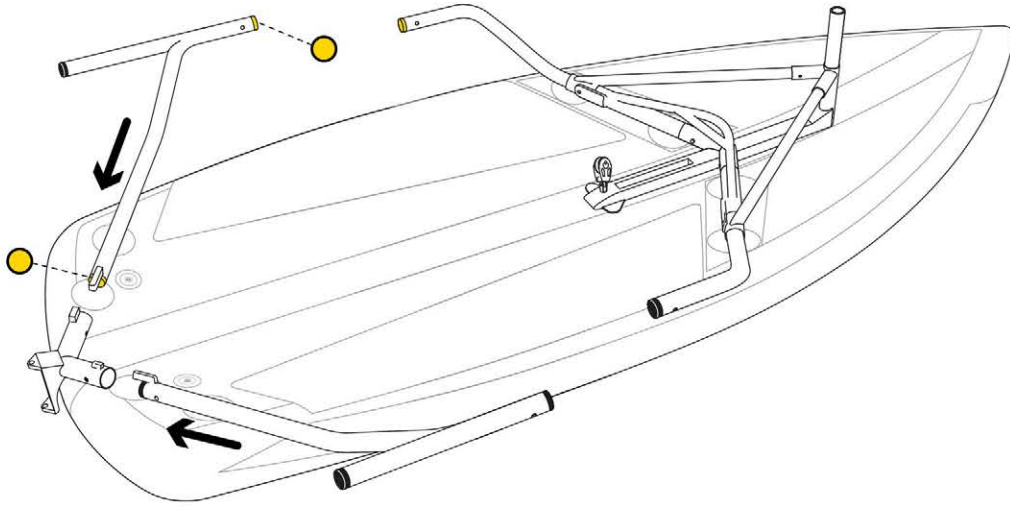

6

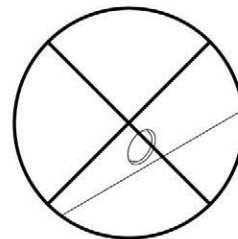
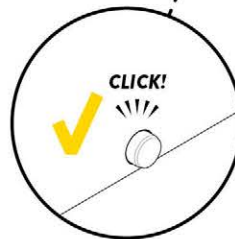
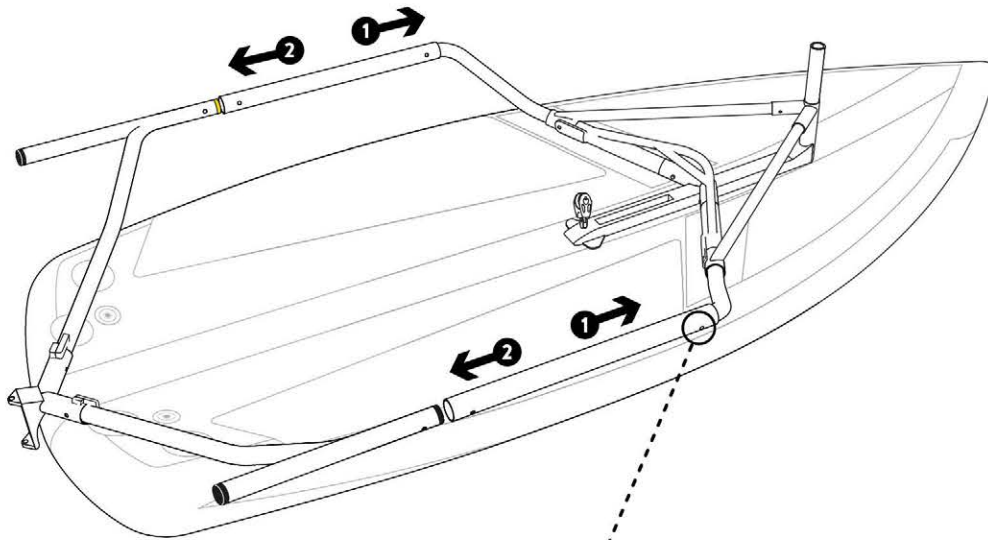

4 5 6

Avoid sand when you assemble the boat.
 Check that all the push-pins are correctly locked into their corresponding sockets otherwise the structure could easily be damaged and you could lose some parts of the boat.

7

7 Check that the transom is centered with the yellow band. Do not let any sand on the hook and loop straps.

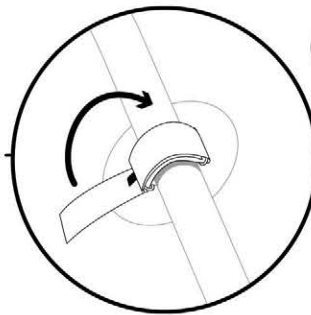
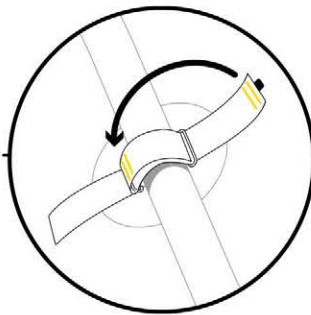
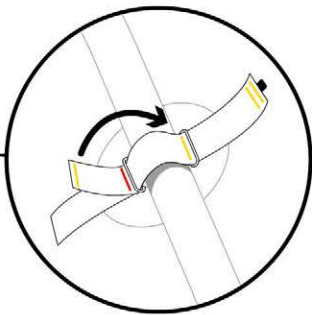
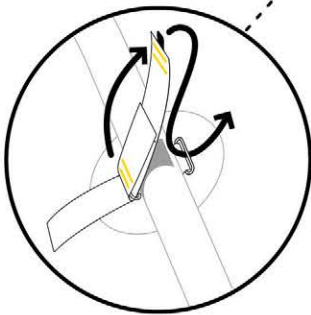
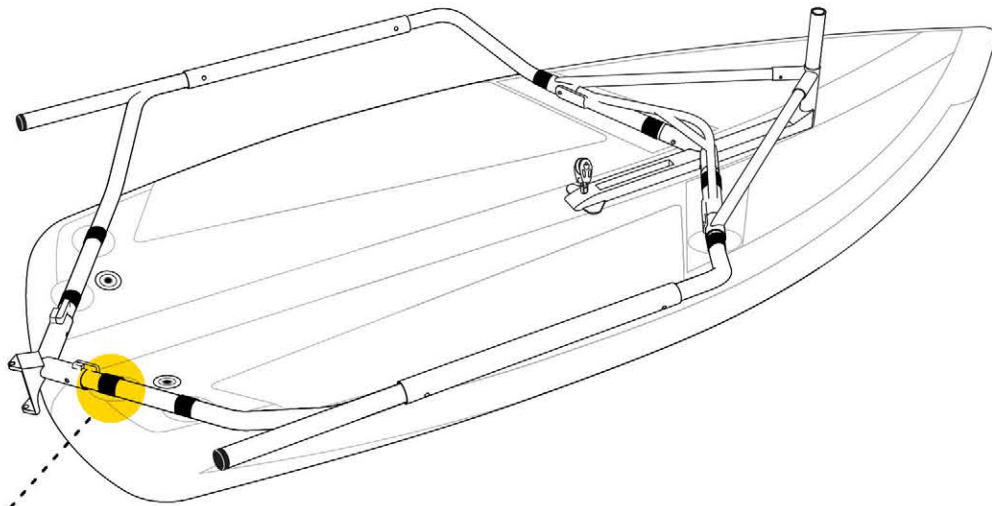

x8

8

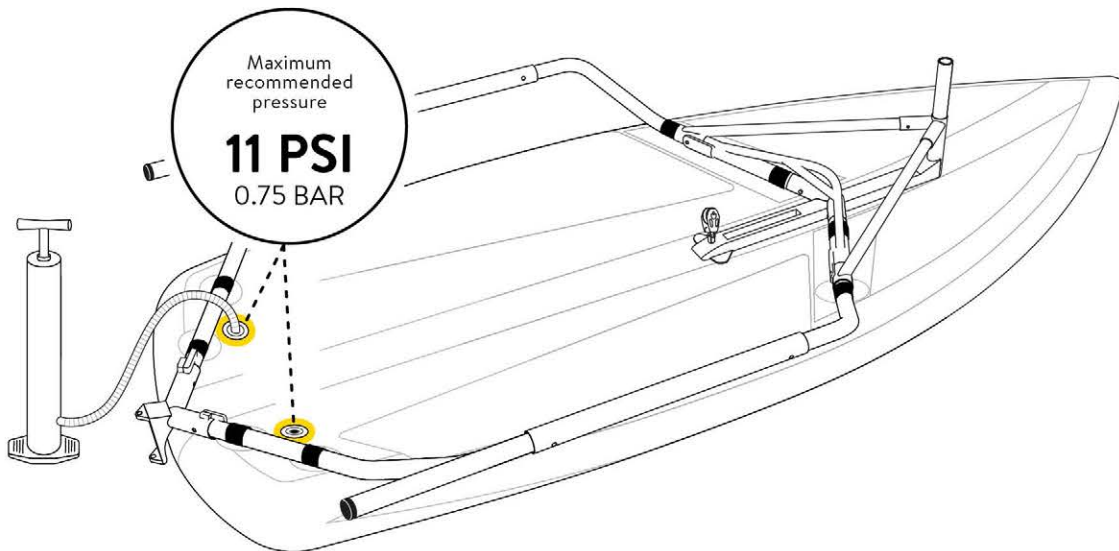

8 To inflate with the manual pump, keep the yellow spring loaded button in the UP position. The pressure gauge of the manual pump may not read any pressure until you reach 0.2 psi. To guarantee high pressure in the hull, it is normal to have to push strongly on the pump handle at the end of the inflation. Recommended pressure: 11 psi MAX. Check that the valves located at the back of the hull are closed before sailing.

9 BATTENS LATTES

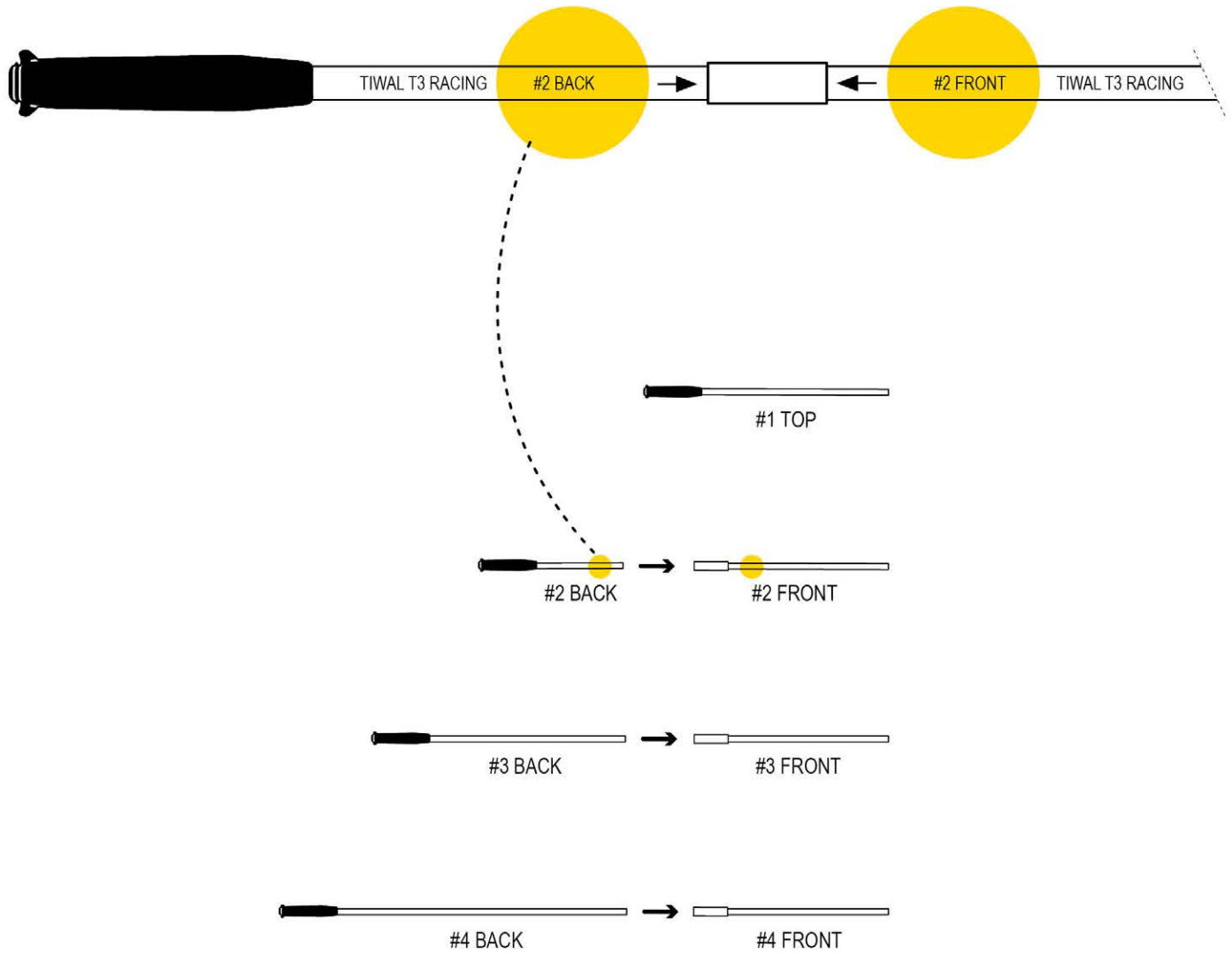

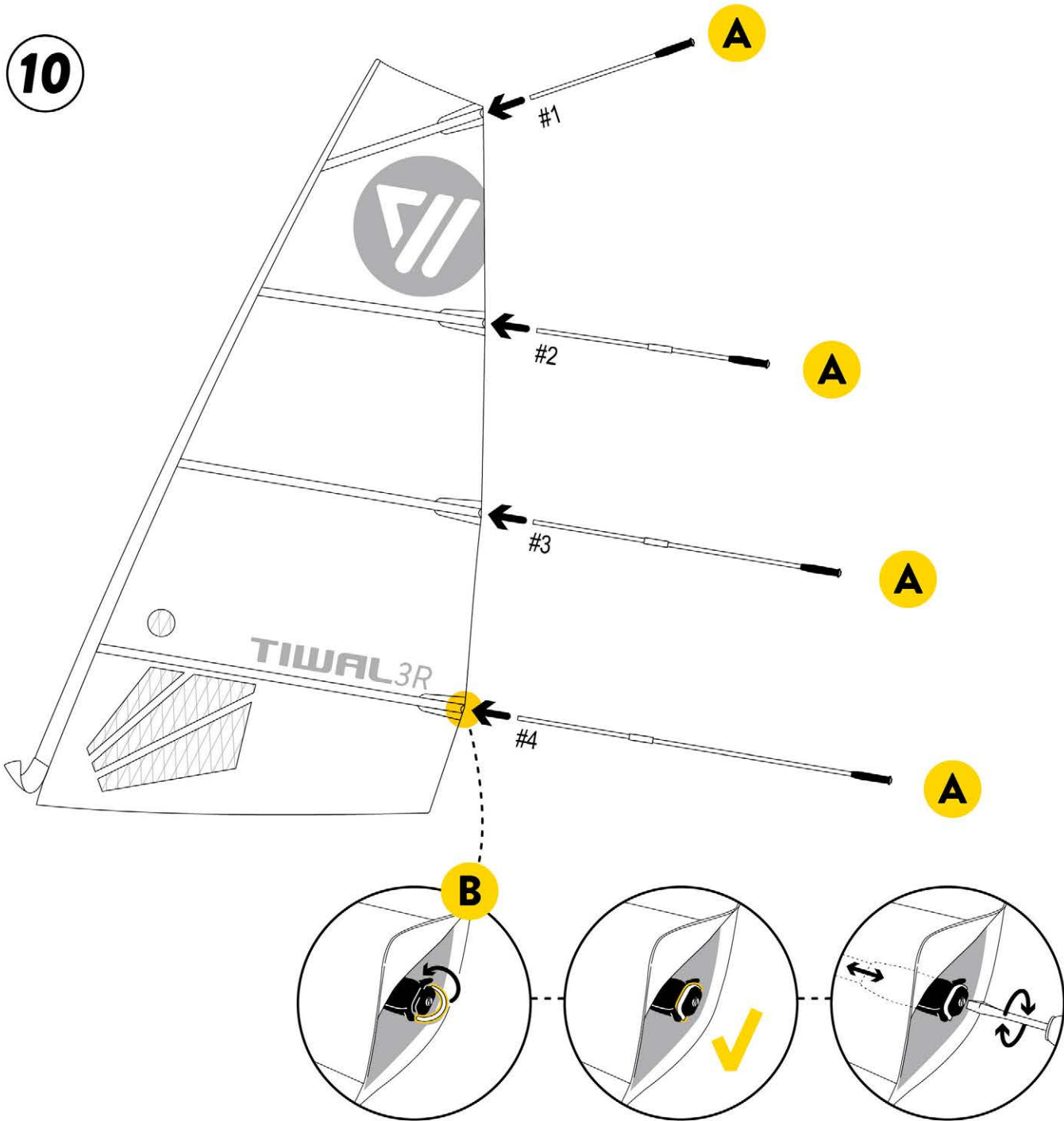

10 B Once the batten is assembled and inserted, fold the white loop over the batten to make it secure. To tension the battens, tighten the screw inside the end cap. To increase the longevity of the sail, remember to release the tension in the battens when you're not sailing or not using for long periods of time. To do this, unscrew the end cap and press down to release the tension.

WIND (BEAUFORT)	1	2	3	4	5
Sail surface area 67 sq. ft	✓	✓	✓	✓	✗
Sail surface area 77 sq. ft	✓	✓	✓	✗	✗

11

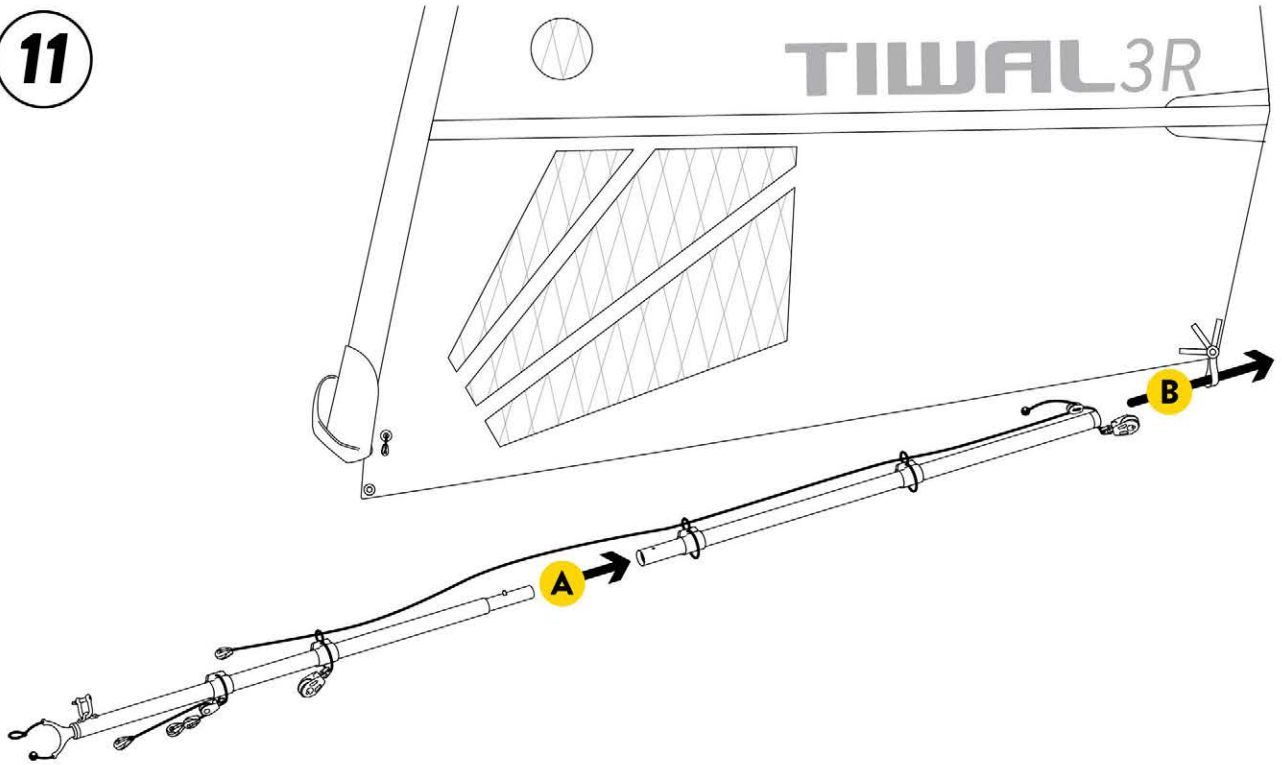

12

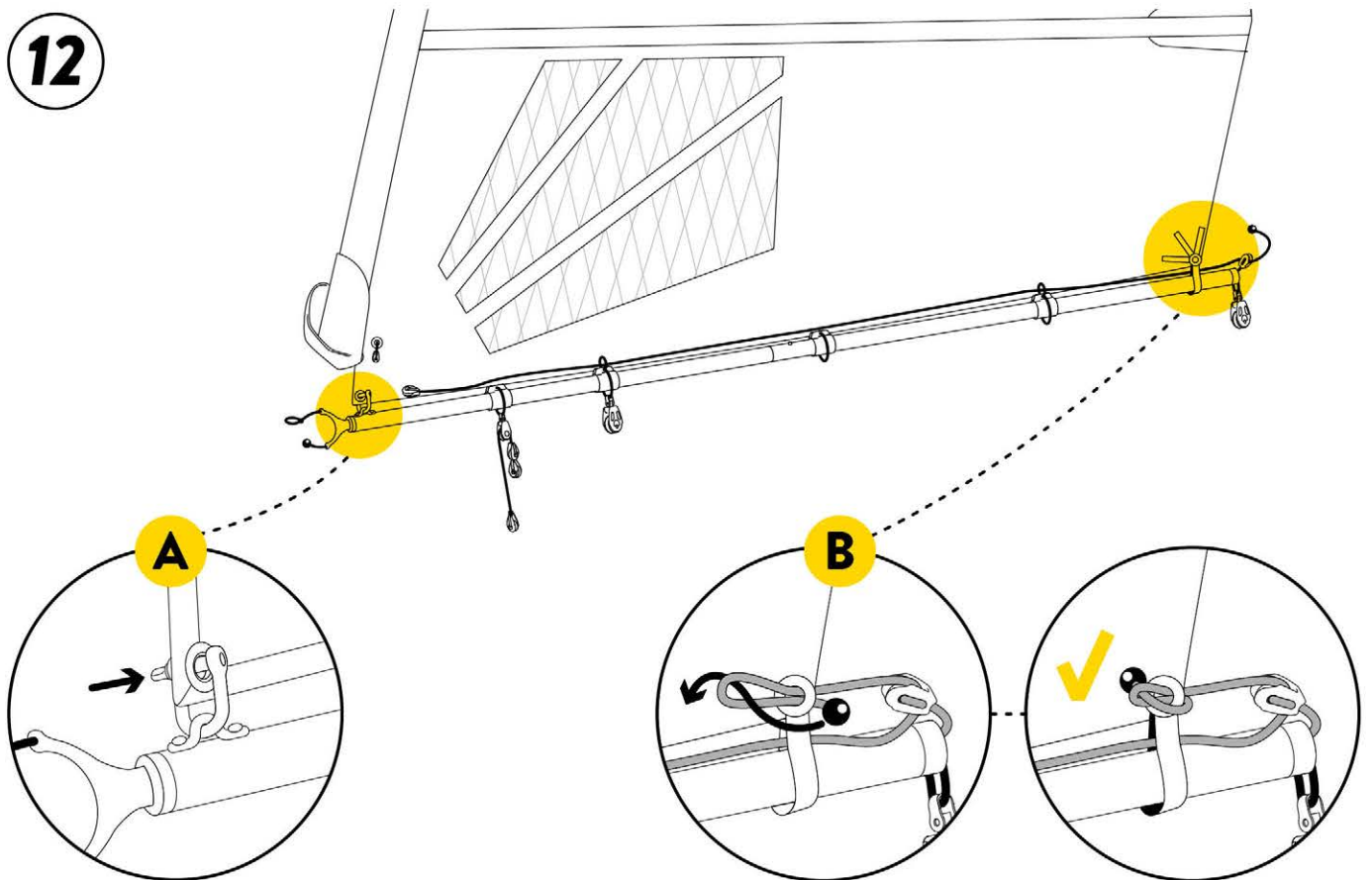

13 MAST

OPTION A

For the 77 sq ft sail, use all 5 parts of the mast.

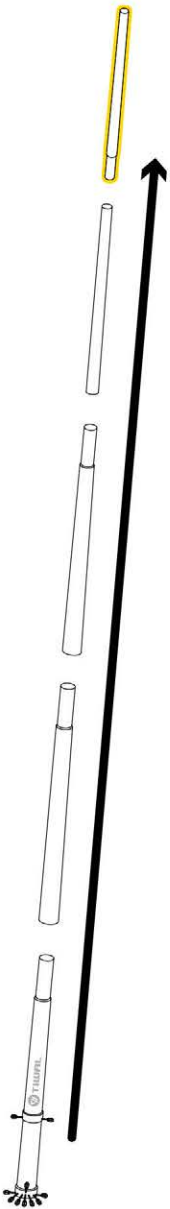

OPTION B

For the 67 sq ft sail, use only the first 4 parts of the mast. Insert the additional mast cap.

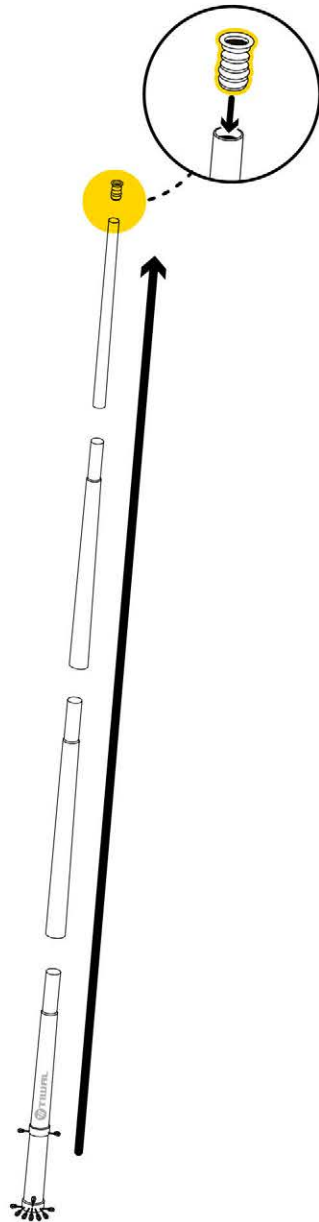

14

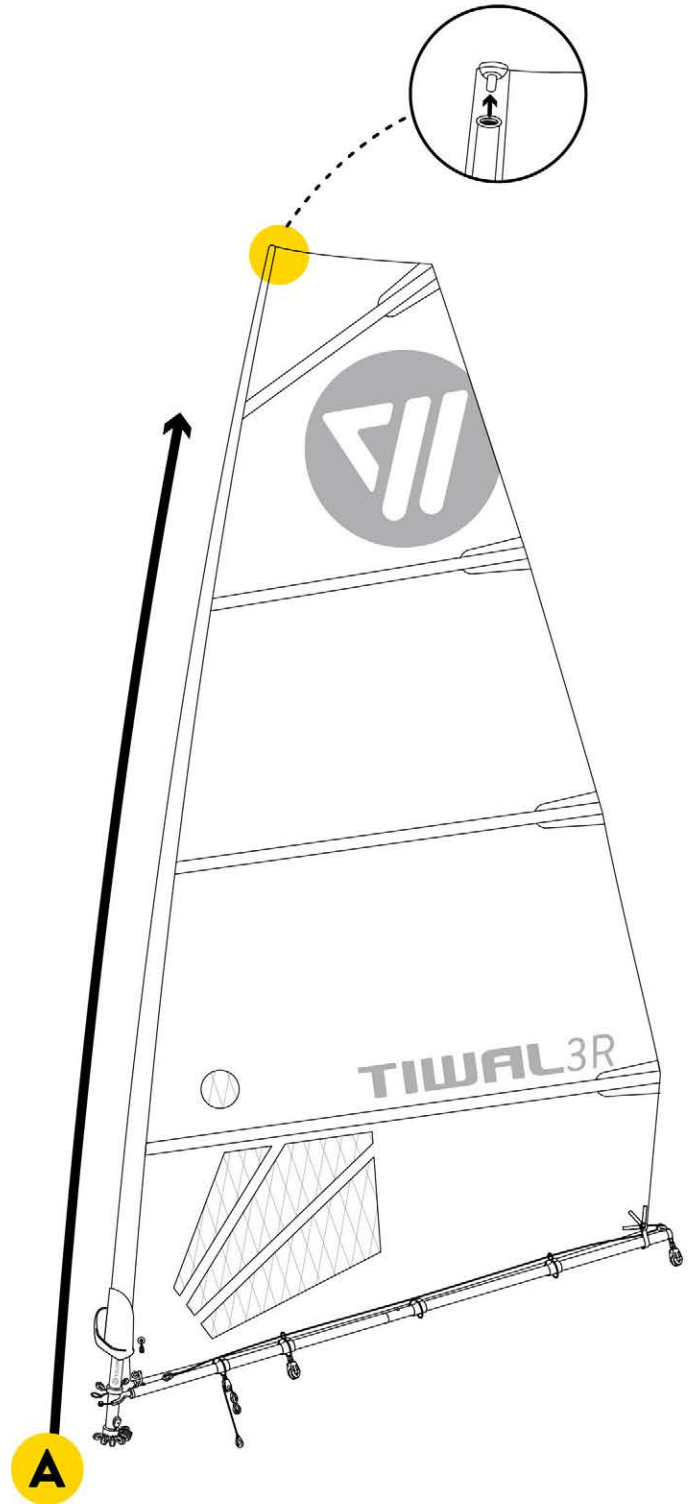

13 Always make sure that there is no sand on the mast or its sleeves before assembly. Ensure that the mast goes all the way to the plastic end cap at the top of the mast sleeve.

15 MAINSHEET

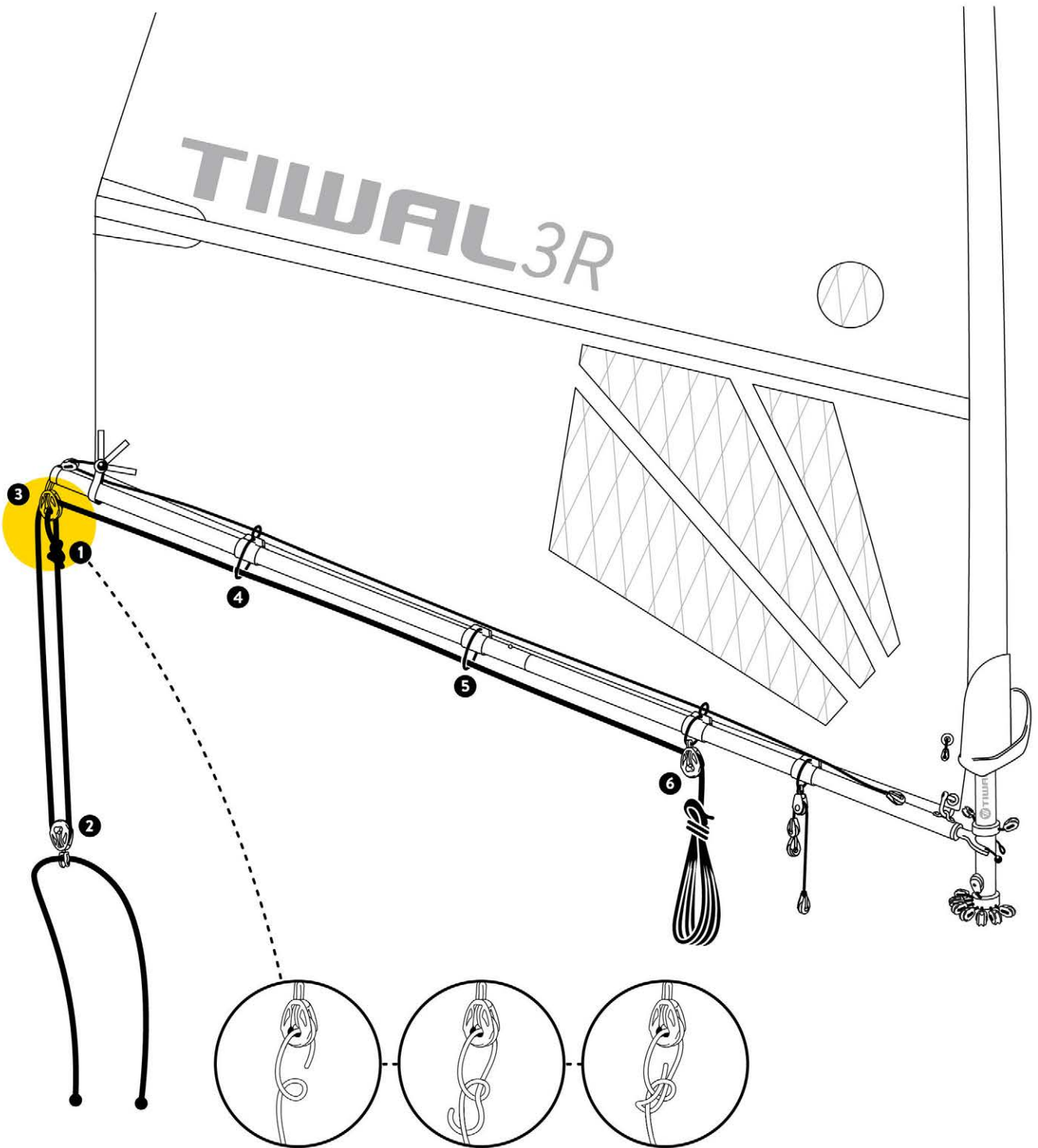

Bowline
Nœud de chaise

16

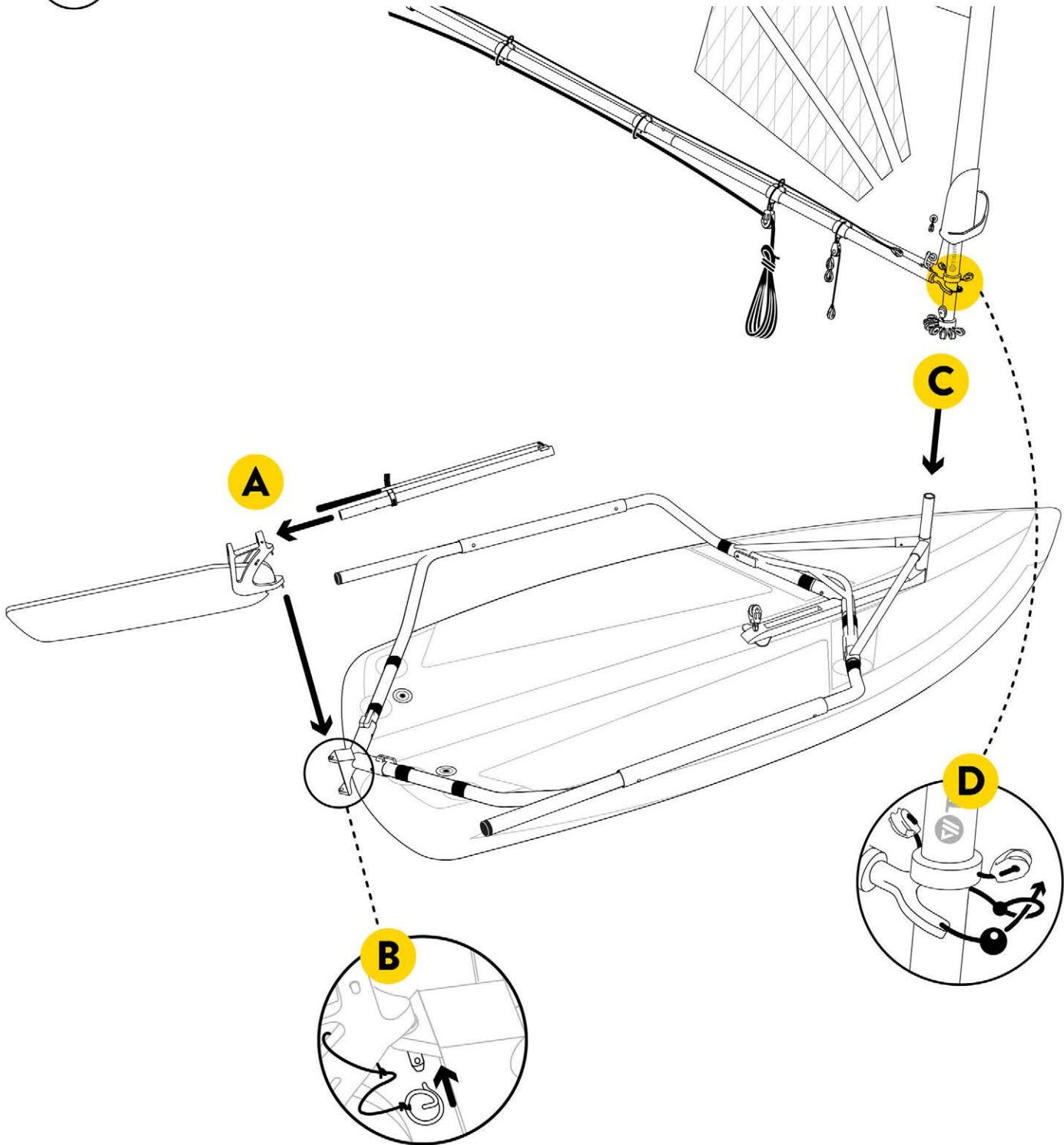

- 16 Before going sailing, make sure the safety pin is inserted in the hole of the rudder pintle (upper). This prevents the rudder from coming out while sailing or in the event of capsizing. Before setting off, always check that the wing nut is done up correctly on the top of the rudder. Screw it up tightly, then slacken it off 1/6 turn so that the rudder is free to rotate. Once under way, readjust the wing nut if necessary.

17 CUNNINGHAM

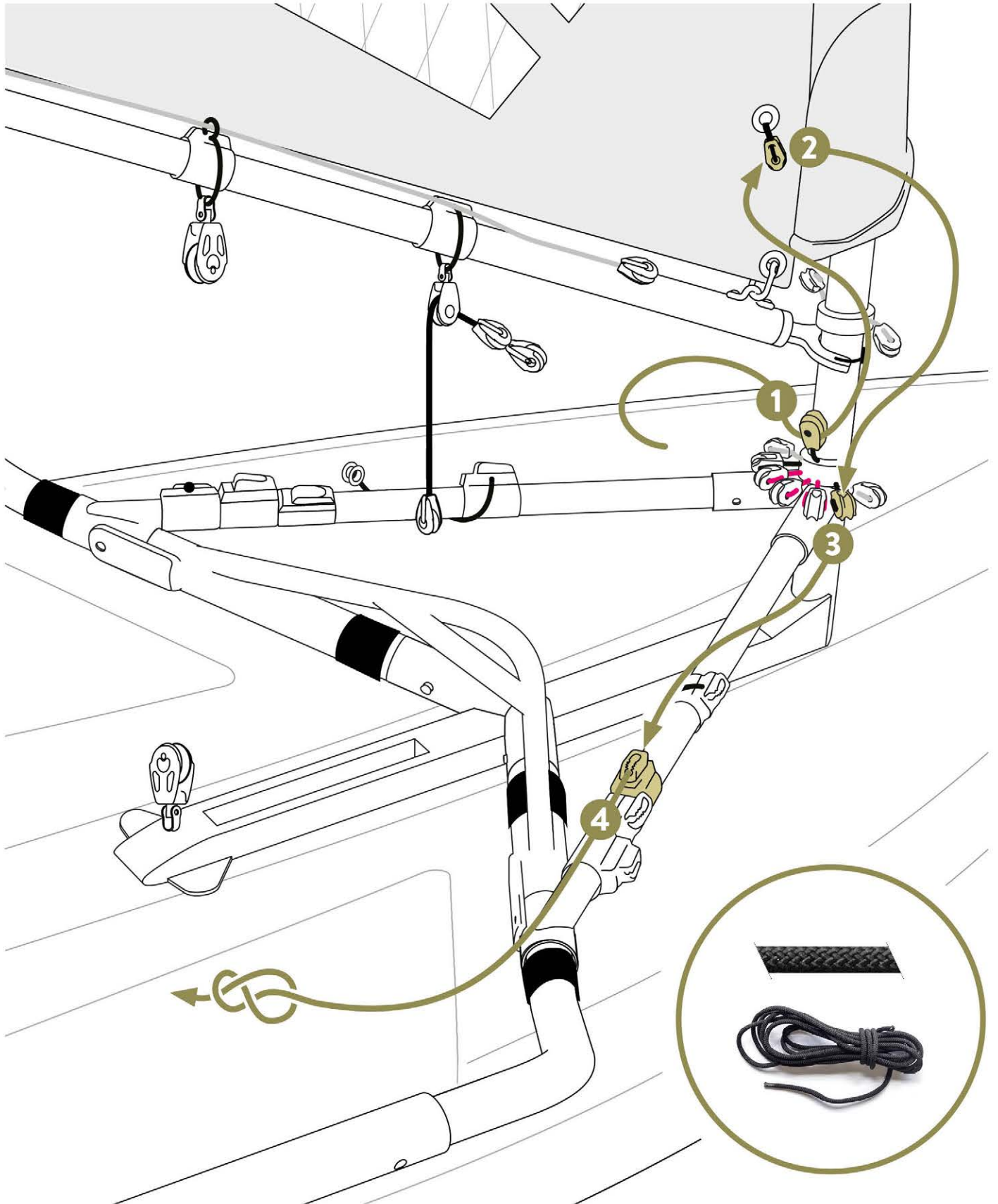

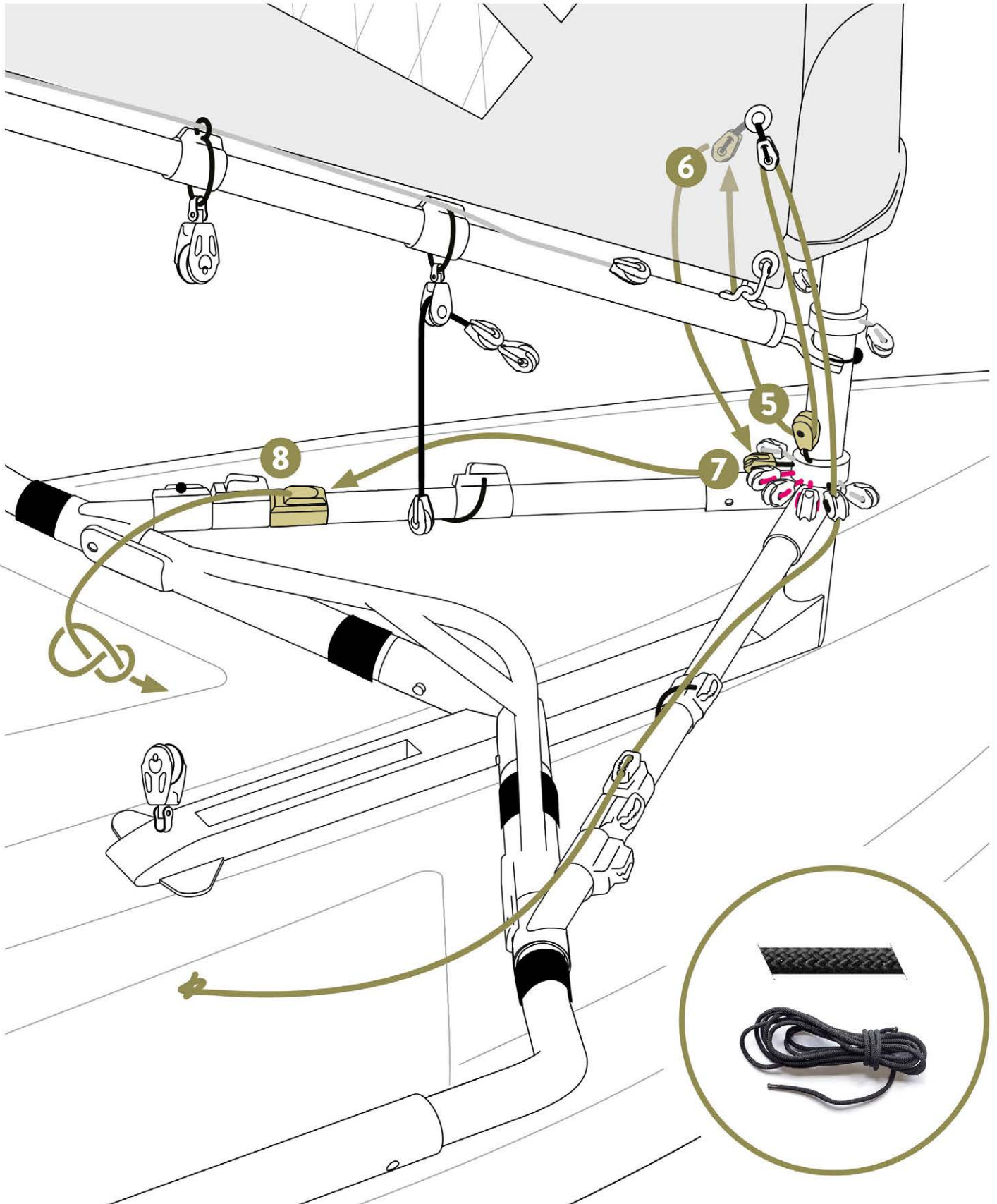

18 BOOM VANG TRAVELER

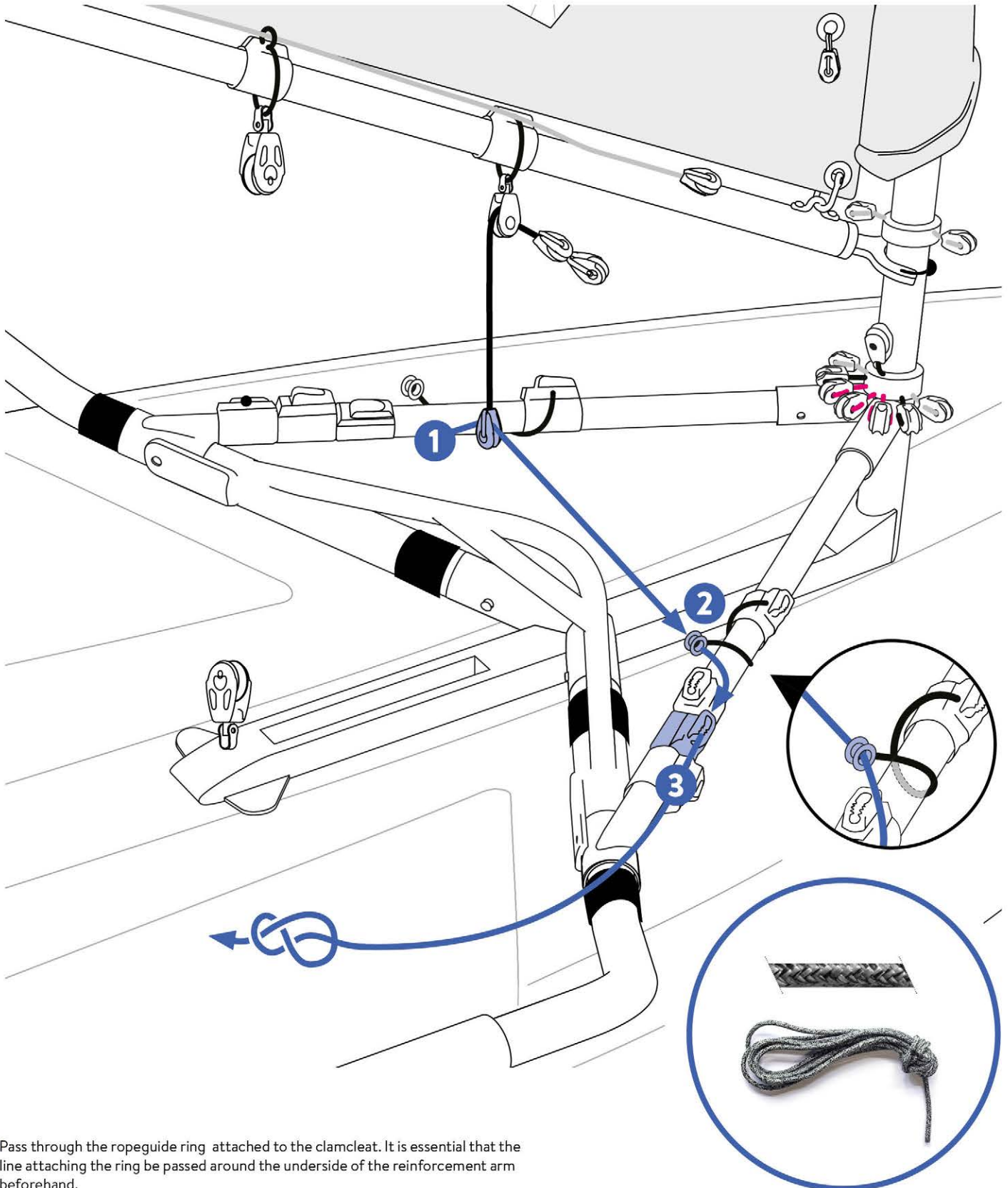

- 2 Pass through the ropeguide ring attached to the clamcleat. It is essential that the line attaching the ring be passed around the underside of the reinforcement arm beforehand.

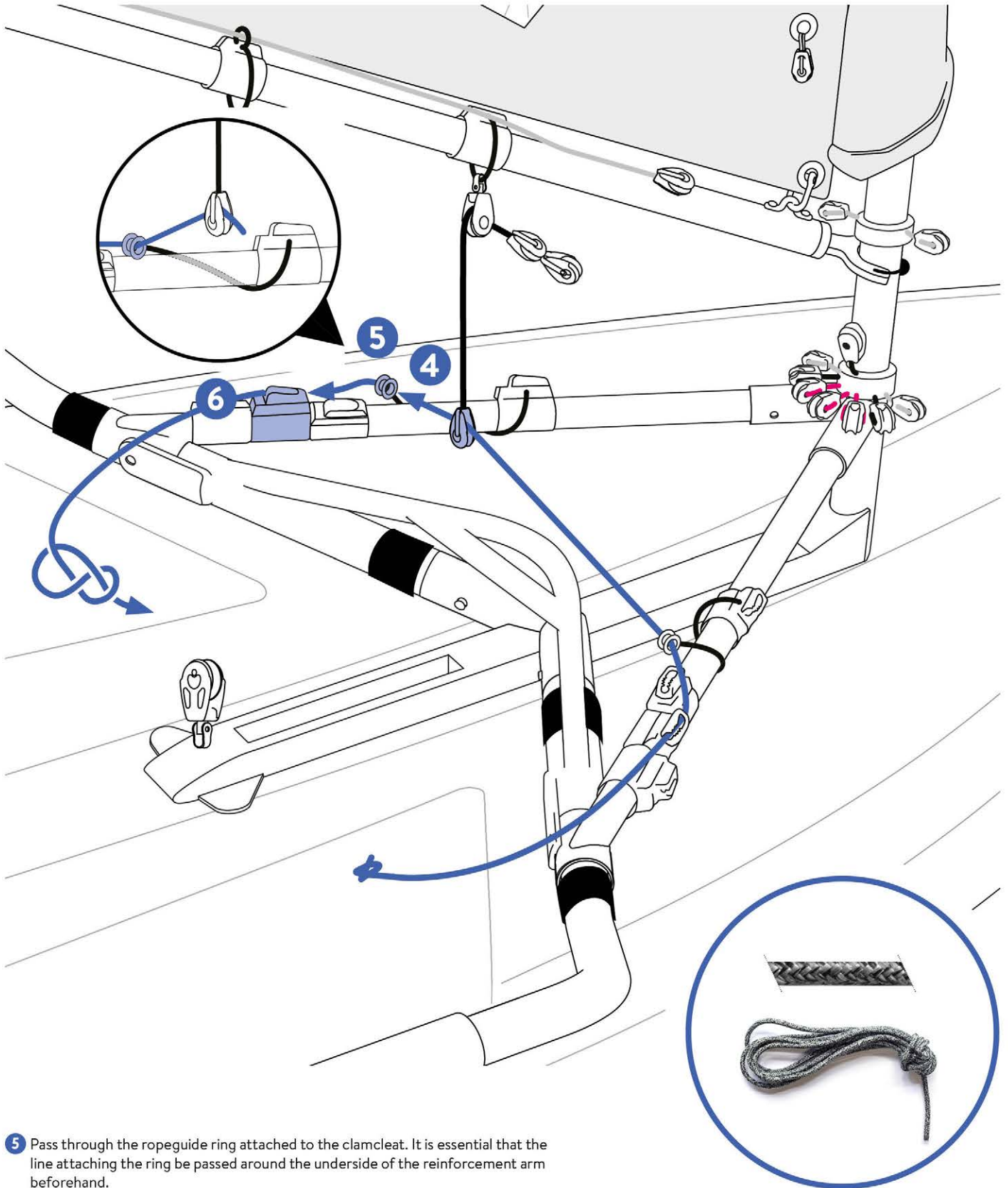

- 5 Pass through the ropeguide ring attached to the clamcleat. It is essential that the line attaching the ring be passed around the underside of the reinforcement arm beforehand.

19 CLEW OUTHAUL

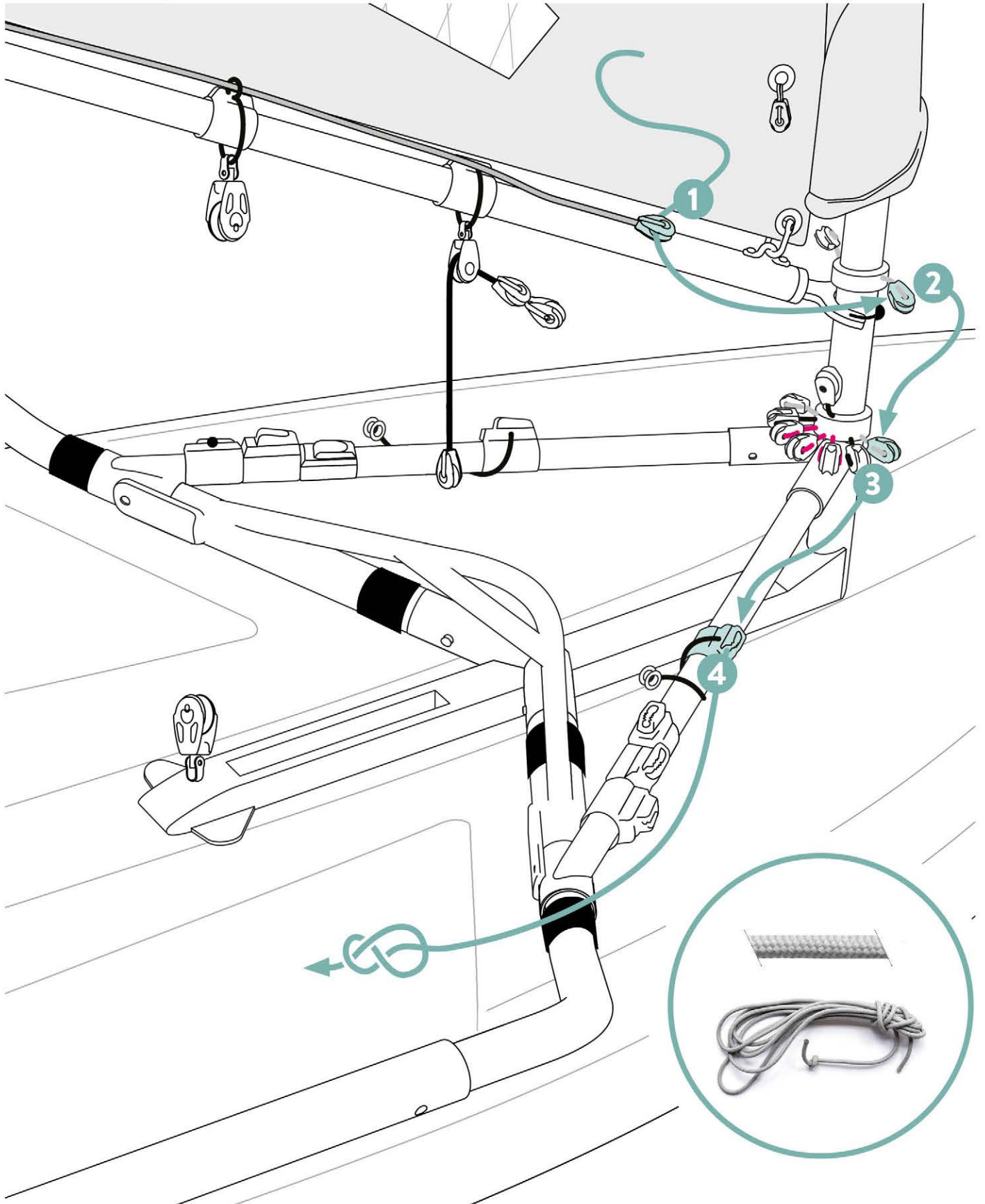

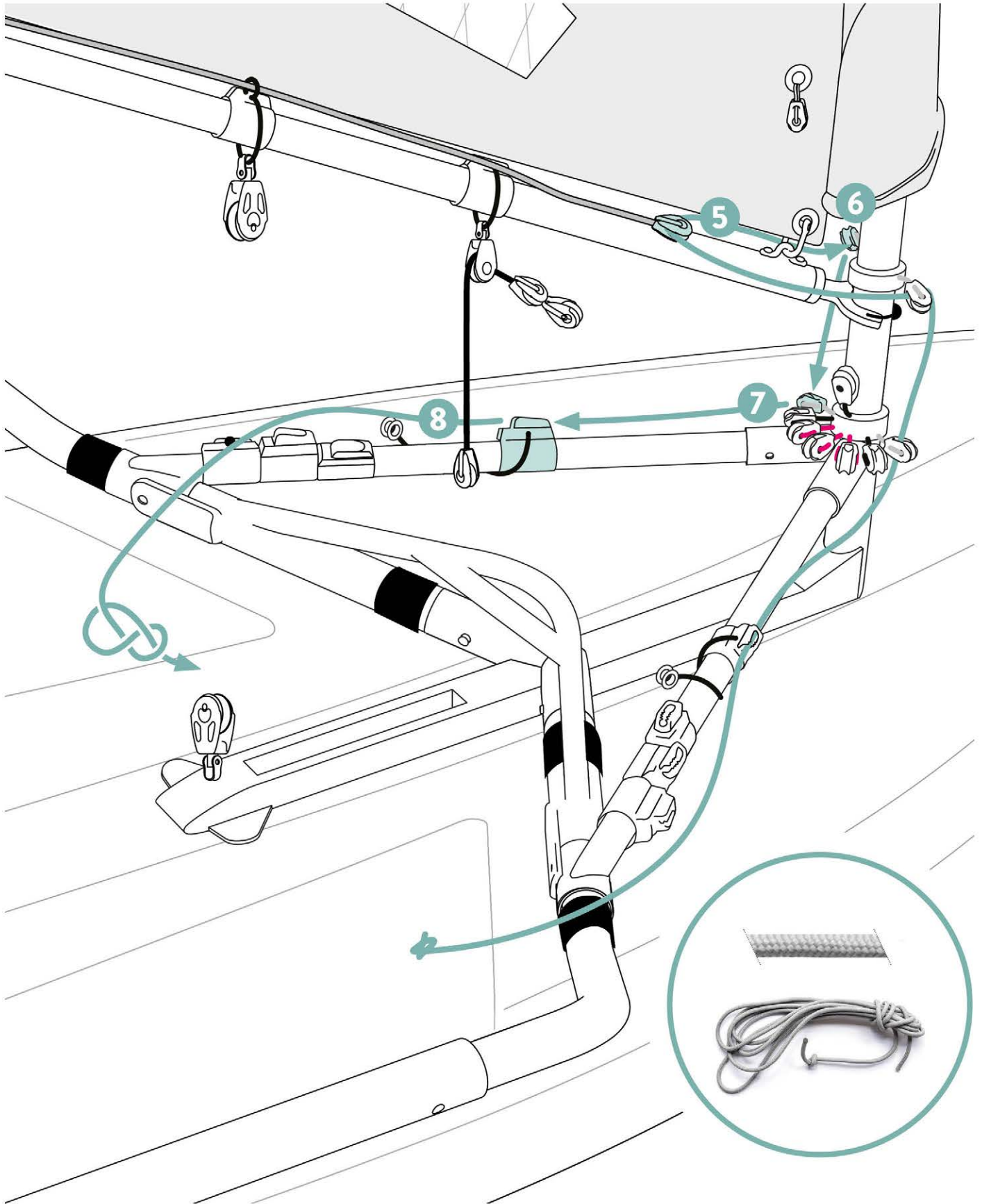

20 VANG

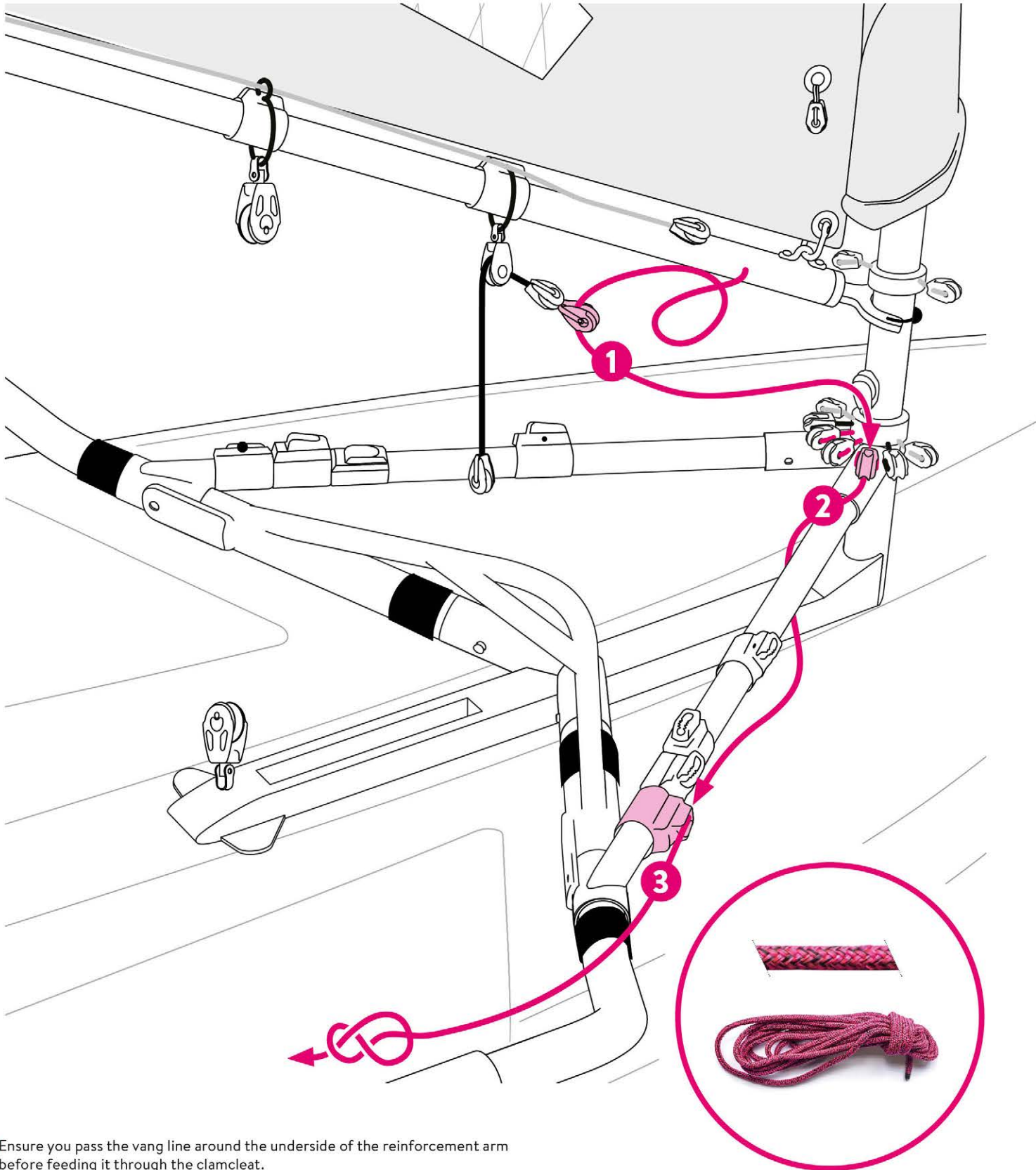

- 2 Ensure you pass the vang line around the underside of the reinforcement arm before feeding it through the clamcleat.

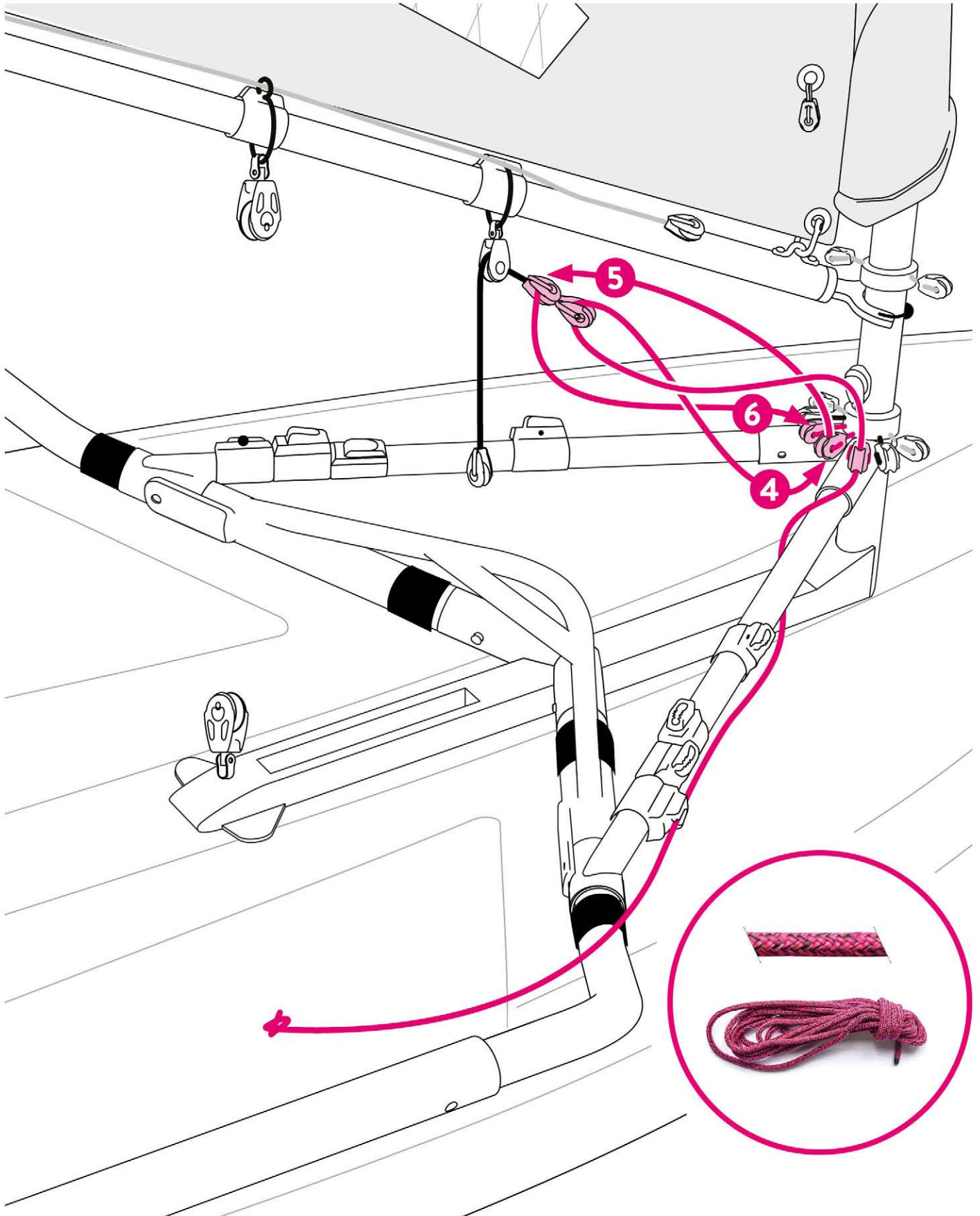

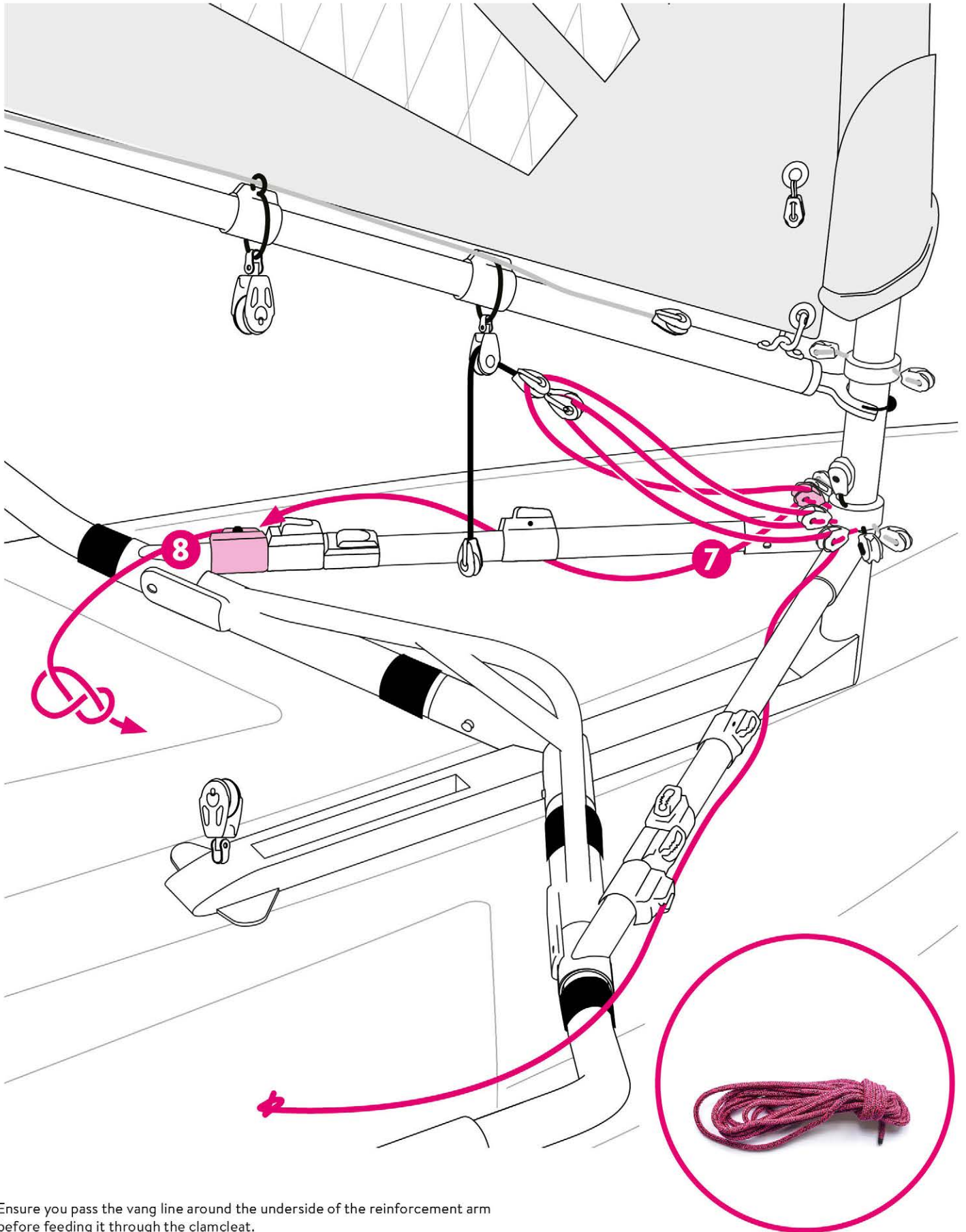

7 Ensure you pass the vang line around the underside of the reinforcement arm before feeding it through the clamcleat.

4 CHECK POINTS



1

Check that the clew outhaul (light gray) passes outside the cunningham (black).

2

Check that the vang (pink) passes round under the reinforcement bar before going through its clamcleat.

3

Check that the line that ties the ropeguide ring goes around the reinforcement arm (passing over the cunningham).

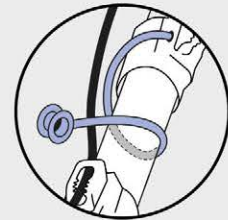

4

Check that each line is in its correct place by using the stickers on the clamcleats and the color of the lashings on each block.



21

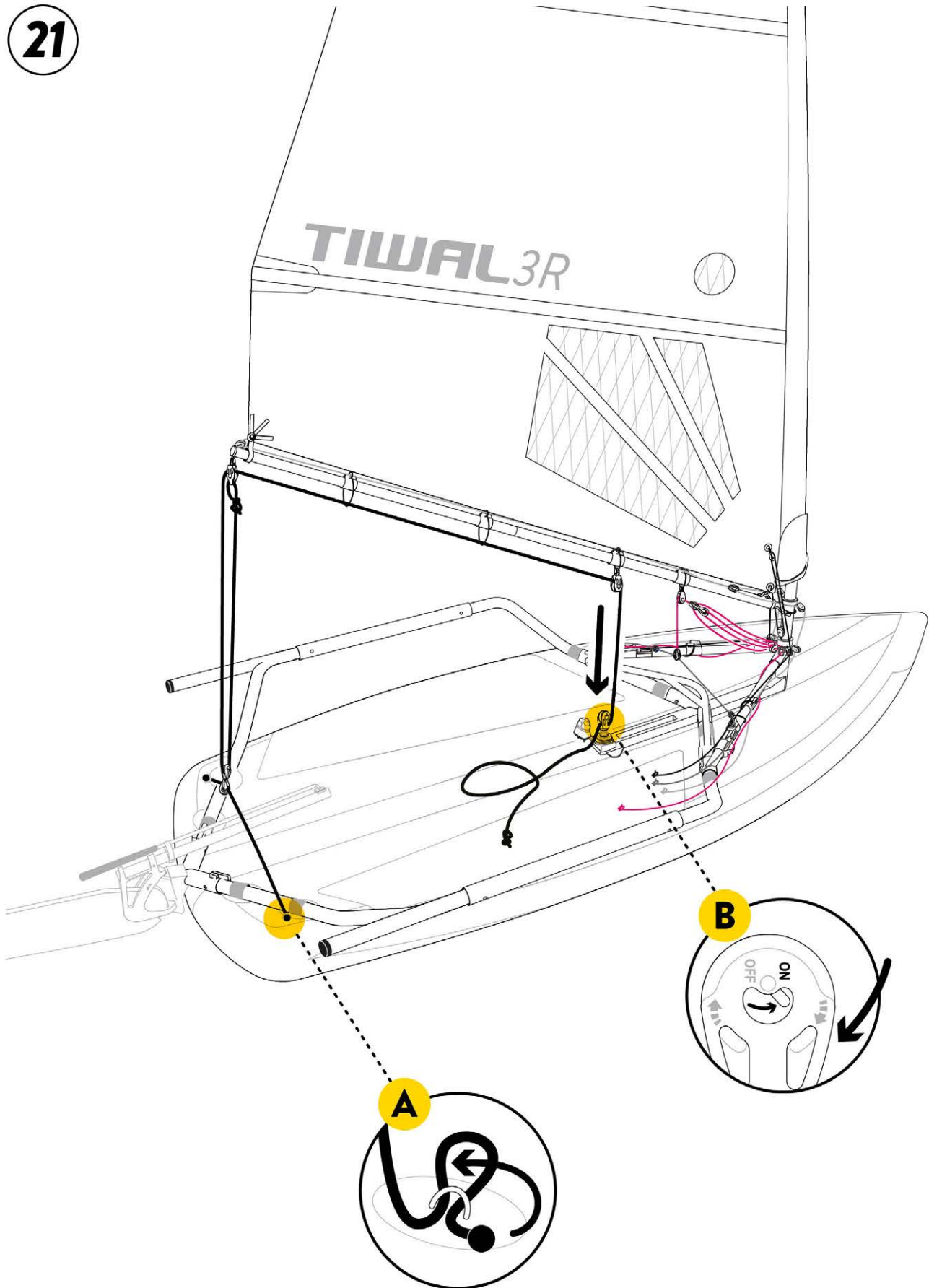

22

Method for attaching the tiller extension to the tiller

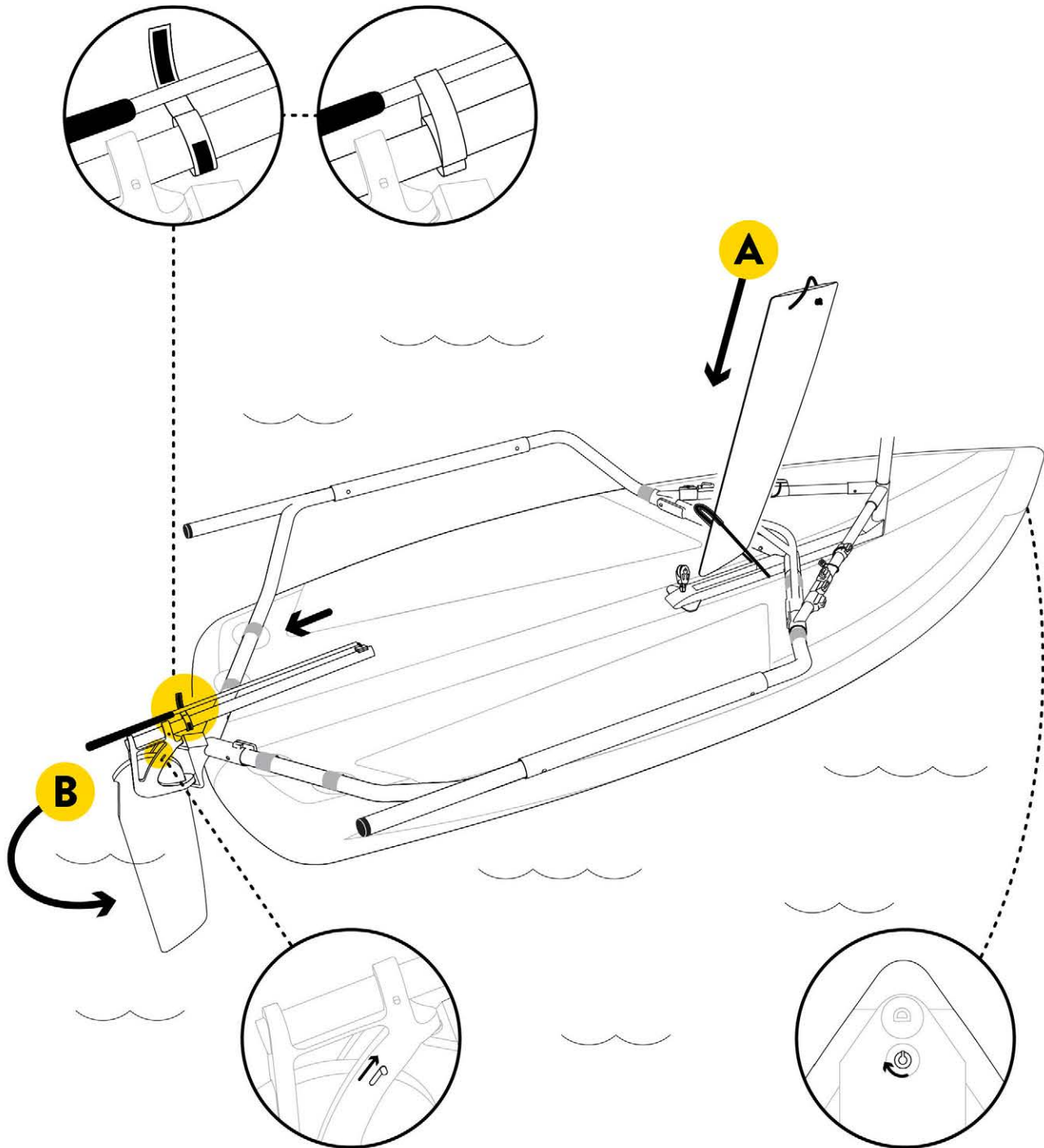

Make sure the drain valve is closed before putting the boat in the water.

SAIL BAG

OPTION A

1

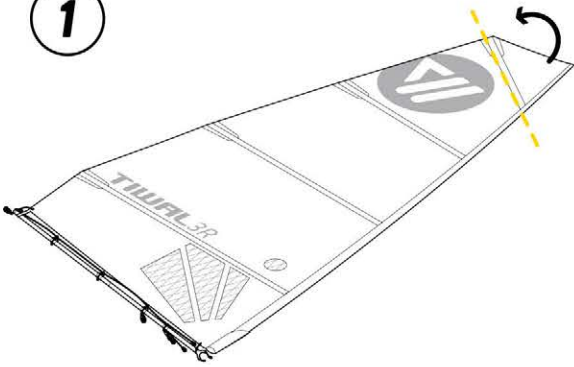

2

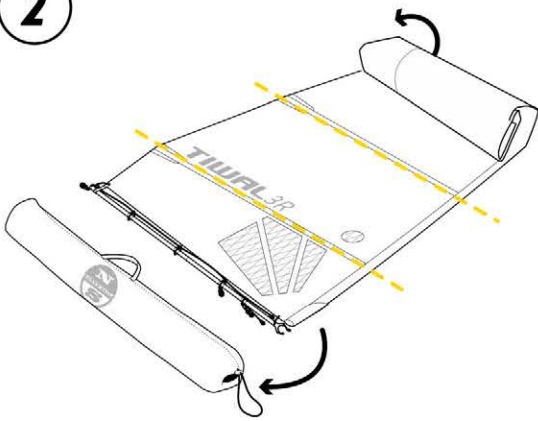

OPTION B

1

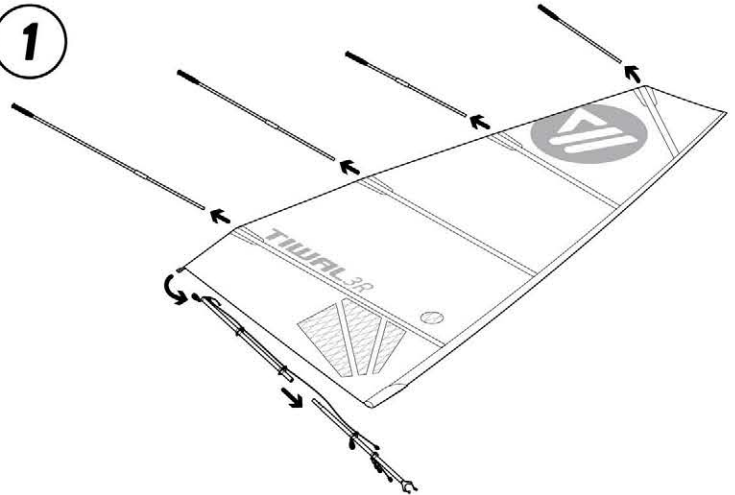

2

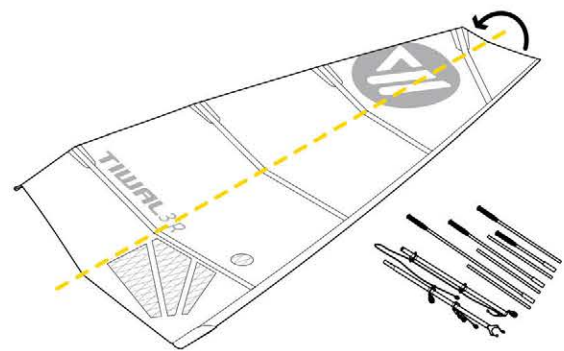

3

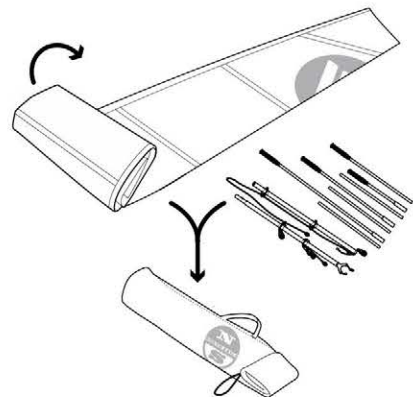

To remove the battens, partially undo the screw in the batten end cap and press the black end cap onto the batten. Then fold down the white ring to pull the batten out.

TIWAL

185 Alewife Brook Parkway - Suite 210
Cambridge MA 02138 U.S.A.

info@tiwal.com

www.tiwal.com

Our boats are manufactured under US Patent No. 9,694,875, CN Patent 103958340, EP 2 768 723

Copyright © 2023 TIWAL. All rights reserved.
Reproduction in whole or in part without written permission is prohibited.